



Q.bloxx A104

Multi Channel Module for Thermocouples and Voltages



The Q.series has been designed for demanding measurements found in today's most industrial measuring and testing environments. The range of applications starts from single stand-alone solutions up to networked multi-channel applications in the field of component testing, engine testing, process performance testing and structural monitoring.

The range and flexibility of the modules allows an optimized solution for each single task: Dynamic signal acquisition up to 100 kHz, inputs and outputs for all types of signals, galvanic isolation of inputs and outputs, multi-channel solutions, high density packaging and intelligent signal conditioning.

Data exchange between Test Controller and automation level is communicated via Ethernet TCP/IP or fieldbus systems like EtherCAT or Profibus-DP and additional Ethernet-based industrial standards.

Most important features:

- **8 galvanic isolated input channels**
thermocouples and voltages in the range of ± 80 mV
Isolation voltage 100 VDC
- **Cold junction compensation**
good thermal coupling by means of cold junction compensation per connector
- **Dynamic linearization**
optimized positioning of the interpolation points within the selected range, type B, E, J, K, L N, R, S, T, U
- **High accuracy digitalization**
24 bit ADC, 100 Hz sample rate per channel,
- **Signal conditioning**
digital filter, average, scaling, min/max storage, arithmetic, alarm
- **RS485 fieldbus-interface**
up to 48 Mbps: LocalBus
up to 115.2 kbps: Modbus-RTU, ASCII
- **Connectable to any Test Controller**
e.g. Q.station, Q.gate or Q.pac
- **Galvanic isolation**
channels to power supply and to interface
Isolation voltage 500 VDC
- **Electromagnetic Compatibility**
according EN 61000-4 and EN 55011
- **Power supply 10...30 VDC**
- **DIN rail mounting (EN 60715)**





Q.bloxx A104

Multi Channel Module for Thermocouples and Voltages

Block Diagram

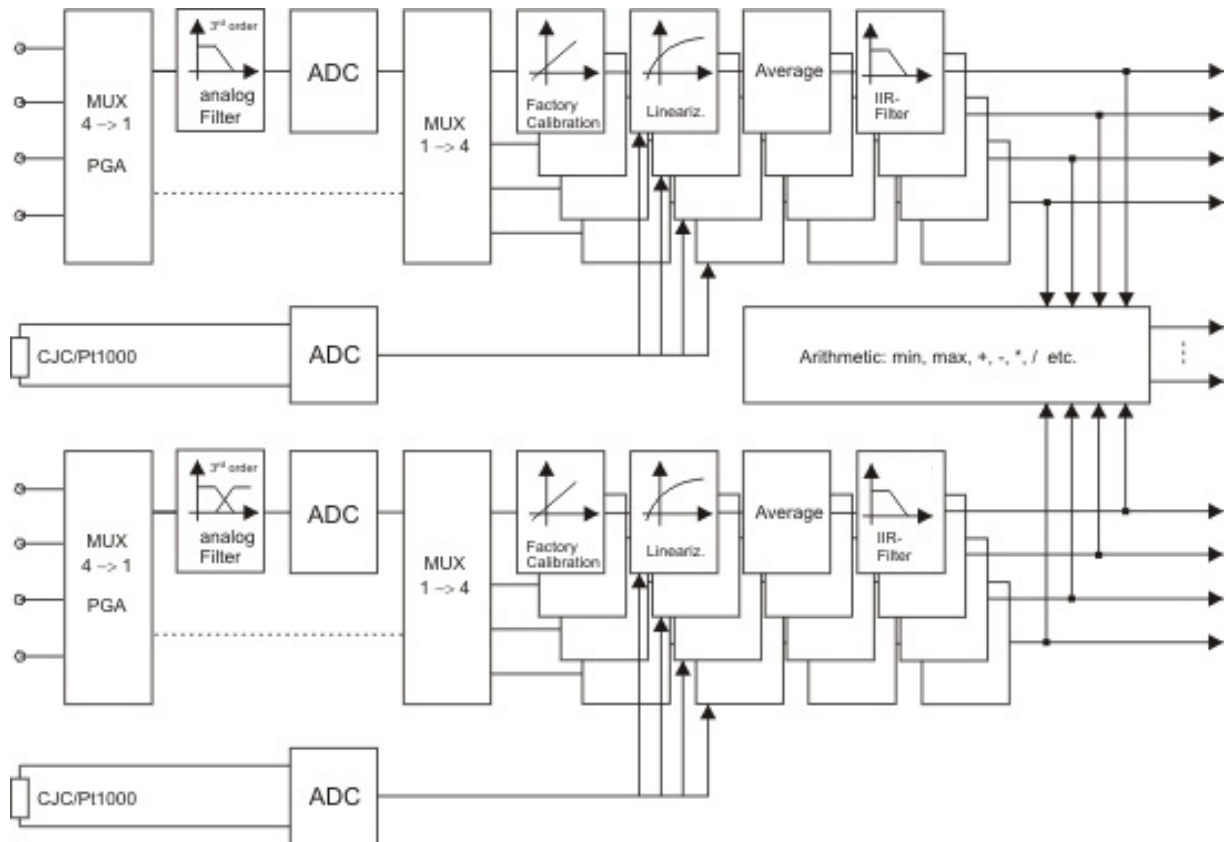

Analog Inputs			
Number	8		
Accuracy	0.01 % typical		
	0.025 % in controlled environment ¹		
	0.05 % in industrial area ²		
Linearity error	0.01 % of the final value typical		
Repeatability	0.003 % typical (within 24 h)		
Input resistance	>10 MΩ		
Isolation voltage	100 VDC permanent channel to channel		
	500 VDC channels to power supply to interface ³		
Measurement Voltage			
	Range	max. Deviation	Resolution
	±80 mV	±10 μV	10 nV
Long term drift	<1 μV / 24 h; <10 μV / 8000 h		
Temperature influence	on zero		on sensitivity
	<1 μV / 10 K		<0.025 % / 10 K
Signal-noise-ratio	>100 dB at 100 Hz		

¹ according EN 61326: 2006, appendix B

² according EN 61326: 2006, appendix A

³ noise pulses up to 1000 VDC, permanent up to 250 VDC



Q.bloxx A104

Multi Channel Module for Thermocouples and Voltages

Measurement Thermocouple	Type	whole range incl. cold junction compens.
	Type B	better than $\pm 2.5^{\circ}\text{C}$ ¹⁾
	Type E, J, K, L, T, U	better than $\pm 0.5^{\circ}\text{C}$ ¹⁾
	Type N	better than $\pm 1^{\circ}\text{C}$ ¹⁾
	Type R, S	better than $\pm 1.5^{\circ}\text{C}$ ¹⁾
Long term drift	<0.025°C / 24 h; <0.05°C / 8000 h	
Temperature influence (Type K)	on zero	on sensitivity
	<0.02°C / 10 K	<0.005 % / 10 K
Uncertainty cold junction compensation	<0.3°C	
Analog/Digital-Conversion		
Resolution	24 bit	
Sample rate	100 Hz each channel	
Conversion method	Sigma-Delta	
Digital filter	variable digital low pass filter 1 st order	
Averaging	sliding 10 x 10 ms for optimization of the precision (always active)	
	in addition optional filter for mains rejection 50 Hz (measuring rate 6 Hz) or 60 Hz (measuring rate 10 Hz)	
Power Supply		
Power supply	10 up to 30 VDC, overvoltage and overload protection	
Power consumption	approx. 2 W	
Influence of the voltage	<0.001 %/V	
Environmental		
Operating temperature	-20°C up to +60°C	
Storage temperature	-40°C up to +85°C	
Relative humidity	5 % up to 95 % at 50°C, non condensing	
Communication Interface		
Standard	RS-485, 2-wire	
Data format	8e1	
Protocols	Local-Bus: 115200 bps up to 48 Mbps	
	Modbus-RTU, ASCII: 19200 bps up to 115200 bps	

¹⁾ with activated mains rejection 50 Hz resp. 60 Hz.



Q.bloxx A104

Multi Channel Module for Thermocouples and Voltages

Mechanical	
Case	Aluminum and ABS
Dimensions (W x H x D)	(27 x 120 x 105) mm
Weight	approx. 200 g
Mounting	DIN EN-rail
Accessory	
Cold Junction Compensation	<p>Connection terminal for 4 thermocouples, thermal embedded Pt1000 temperature sensor 2 terminals each module required (8 thermocouples)</p> 

Warm Up Time

All declarations are valid after a warm up time of 45 minutes.

Valid from Juli 2015. Specification subject to change without notice
DB_Q.bloxx_A104_E_22.docx