

# PQM3000RGW

## Class A rack 19" power quality analyzer with Rogowski coils

- Rack 19" mounting
- Current inputs for direct connection of Rogowski coils
- Harmonics and interharmonics measurement
- Data recording for further EN 50160 analysis
- Data recorded in standard PQDIF and CSV file formats
- Embedded web server
- Communication on Ethernet and 3G networks
- Included external GPS module for accurate timing
- Internal rechargeable backup battery
- Certified according to **IEC/EN 61000-4-30:2015 Ed.3**, Class A for voltage characteristics



### » General features

PQM3000RGW is a high-end power quality analyzer, able to monitor and record the major power quality parameters. It provides an accurate measurement, voltage characteristics are monitored according to Class A specification. At the same time it acts as event/fault recorder, capable to store a high number of voltage events and disturbances, frequency variations, inrush current, etc. Additional PQ data can be recorded, such as Flicker, Unbalance, Harmonics and Interharmonics, Mains Signalling. It also provides standard power measurement data for three-phase systems. Extra voltage and current measurement channels give the possibility to monitor Neutral Potential and Earth Leakage current.

Innovative Rogowski coils are included together with the instrument to grant a complete measurement system as well as quick installation. Their current full scale can be programmed among three default values, simply selectable in the device setup, to ensure maximum flexibility even on existing plants.

The powerful recording features give the possibility to capture and record all types of standard and PQ data simultaneously. All this information can be recorded for long time period due to the high memory capacity, in this way a complete EN 50160 analysis can be performed. Events and disturbances provide also waveform recording together with RMS values. Recordings can be transferred in different ways: user can download them directly through web interface or set an automatic scheduled data upload to a remote server.

PQM3000RGW includes different communication ports so the user can access it in different ways. The Ethernet ports on the front and rear panels allow complete control on the instrument: web access for real-time monitor, device setup, stored data transfer, maintenance operations. The integrated mobile network router gives the possibility to manage the device by using 3G network if the Ethernet communication is not available. The RS485 port is dedicated to data reading of PQMGPS1, i.e. the external GPS module provided with the instrument. PQMGPS1 provides accurate time information regardless of the location where the meter is installed in a distributed monitoring system.

Moreover, different I/O channels are provided to enhance the instrument features. An user-friendly multilingual interface is provided for web server which simplify the full access to instrument operations.

### » Benefits

- Additional voltage and current measurement channels in comparison with other standard three-phase devices.
- Rogowski coils included to grant a quick installation as well as an accurate current measurement.
- Continuous monitoring of the power quality and Class A certified measurements for voltage characteristics.
- Simultaneous recording of events, Min/Avg/Max LOG and energy counters.
- Several possibilities for instrument data transmission: Ethernet, Modbus TCP, 3G network.
- User-friendly instrument web interface with multilingual pages.

### » Applications

- Power monitoring & control systems
- Switchboards, gensets, motor control centers, etc.
- Individual machine load monitoring
- Power demand analysis and management
- Harmonics monitoring
- Remote metering and cost allocation
- Motor inrush current studies

### » Related products

- *MFC150* Rogowski coils
- *PQMGPS1* external GPS module
- *PQM-Tool* Class A monitoring software tool
- *PQM-Analyzer* for data analysis according EN 50160

## » Main features

### Measurements

- Voltage direct connection up to 1000 VLL or through PT for MV and HV systems.
- 4th voltage channel for measurement of potential difference between Neutral and Protective Earth.
- 5 current channels to be used with the included Rogowski coils.
- 4th current channel dedicated for Neutral current, selectable in 3 different scales together with the three phase current channels (500 A, 3000 A, 20000 A).
- 5th current channel reserved for Earth Leakage monitoring, with separate current measuring range setup to ensure different sensitivity from the main channels (50 A, 500 A).
- Three-phase 3 and 4 wire or single-phase operating mode.
- Suitable for 50 and 60 Hz systems.
- Fast simultaneous sampling on all 9 channels, at 1024 samples/cycle.
- All measured voltage characteristics certified according to IEC/EN 61000-4-30:2015 Ed.3, Class A.
- Measurement of additional power quality parameters, such as K Factor.

### Recordings & data storage

- Voltage event recording (sags, swells, interruptions) with storage of ½c RMS values and waveforms.
- Sag/swell recording on 4th voltage channel with storage of ½c RMS values and waveforms.
- Rapid Voltage Changes measurement and event recording.
- Power frequency variation monitoring and recording with ½c RMS values and waveforms.
- "Slow" event recording on Frequency, Unbalance Ratio, Flicker, Voltage THD and Mains Signalling variations.
- Overcurrent recording on three-phase current channels with storage of ½c RMS values and waveforms.
- Data LOG function for Min/Avg/Max values of selectable parameters, at programmable rate.
- Energy counter LOG at programmable rate.
- Functional event LOG to report the changes of device operating status, useful to keep the instrument condition under control.
- Digital input status change LOG.
- Automatic data upload to FTP server started by frequency events or scheduled at preset time day by day.
- Recordings containing big amount of data ½c RMS with waveform and Min/Avg/Max are recorded directly in standard PQDIF files.
- For other type of recordings, "slow" events, Energy LOG, Functional LOG, Digital input LOG, data is provided in standard CSV files.
- In case of a failure on the PQM auxiliary power line, the monitoring and recording functions remains active due to the backup battery.

### Inputs & outputs

- 11 isolated digital inputs for remote management of control signals.
- 4 isolated analog outputs for real time parameter variation transmission.

### Communication

- Two Ethernet ports, one designed for a permanent installation on the instrument rear and one for occasional connections on the front panel.
- RS485 port dedicated for GPS data reading.
- Integrated router for 3G mobile communication useful if Ethernet connection is not possible.

### Data analysis

- Standard file formats gives the possibility to have a quick view and analysis on all stored data without any special software.
- PQM-Analyzer software is provided to perform statistical analysis and generate reports on recorded data according to EN 50160 PQ standard.

## » Technical drawing (mm)

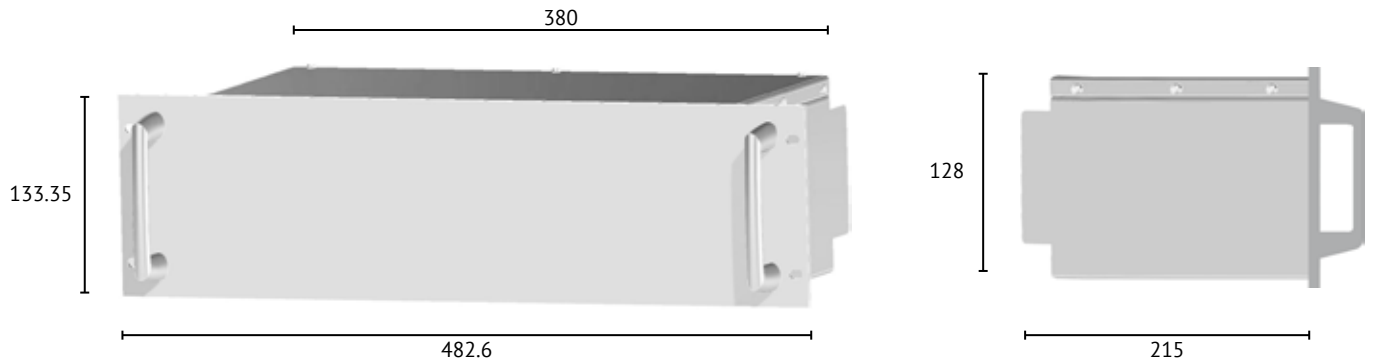

## » Parameters overview

PARAMETER GROUP	LIST	MEASURE	EVENT	LOG	OUTPUTS
Voltages	ULN, ULL, U4N, U4L, U $\Sigma$	●	●	●	●
Currents	IL, IN, IEL, I $\Sigma$	●	●	●	●
Powers	PL- $\Sigma$ , QL- $\Sigma$ , SL- $\Sigma$	●		●	●
Power Factors	TPFL- $\Sigma$ , DPFL	●		●	●
Frequency	F	●	●	●	●
Phase Order	-	●			
Volt Symmetrical Components	U0, U1, U2	●		●	●
Volt Unbalance Ratios	u0, u2	●	●	●	
Volt Deviations (under, over)	ULN, ULL	●			●
Flickers	PinstL, PstL, PltL	●	●	●	
Harmonics up to 50th & Interharmonics	ULN, ULL, IL, PL, QL	●		●	●
Total Harmonic Distortions and K Factors	ULN, ULL, IL, KL	●	●	●	●
Mains Signallings	5 x ULN	●			
Phase Angles	U-U, U-I	●			●
Energy Counters (4Q)	active, reactive, app. $\Sigma$	●		■	●
Rapid Voltage Changes	ULN		●		
Flagging	Sag, Swell, Interruption			●	
Aggregated values	Voltage characteristics	●			
Waveforms	ULN, ULL, IL	●	●		
Mean values	ULN, F, Flicker, Unbal, THDU	□	●		

## NOTES:

- Some of the parameters are not available for all functions, for more details refer to the user manual.
- LOG function means Min/Avg/Max recording, except for Energy counters (■).
- Parameters in MEASURE column can be displayed or read by communication port, except for Mean values (□).

## » Specifications

### POWER SUPPLY

Auxiliary power voltage:	85...285 VAC 50/60 Hz / 65...250 VDC
Auxiliary power consumption:	15 VA max
Fuse:	250 VAC / 500 mA T type delayed
Backup battery:	Li-Ion, 2500 mAh (>15 min autonomy)

### MEASUREMENT INPUTS

Three-phase voltage inputs for direct connection / PT:	P-N: max 580 V RMS CAT III, L-L: max 1000 V RMS CAT III
U4 voltage input for direct connection:	max 580 V RMS CAT III
Voltage input crest factor:	2
Voltage input impedance:	>2 M $\Omega$ /phase
Current full scale:	selectable 500A, 3kA, 20kA RMS; for I5 50A, 500A
Current input crest factor:	3
Frequency range:	42.5...57.5 Hz / 51...69 Hz
Frequency reference channel:	Phase 1/Line 12 voltage
Sampling:	Simultaneous, 51.2 kHz @50 Hz

### ACCURACY

Three-phase voltage:	$\pm 0.1\%$ $U_n$ over 10 ... 150% $U_n$ range
U4 voltage:	$\pm 0.2\%$ measurement
Currents:	$\pm 0.2\%$ measurement (device)
Powers:	$\pm 0.2\%$ measurement
Frequency:	$\pm 8$ mHz
Harmonics:	Class 1 (IEC/EN 61000-4-7)
Realtime clock (RTC):	<1s in 24h without synchronisation; <5ms with GPS synchronisation
Active energy:	Class 0.5S, compliant to IEC/EN 62053-22
Reactive energy:	Class 1, compliant to IEC/EN 62053-23

### I/O CHANNELS

Digital inputs:	11 optoisolated, 24 VDC $\pm 20\%$
1PPS synchronisation input:	1 optoisolated, 24 VDC $\pm 20\%$
Analog outputs:	4 optoisolated, 4 ... 20 mADC, max load 500 $\Omega$
Digital input delay time:	max 10 ms
1PPS input delay time:	max 50 ns
Digital input consumption:	max 7 mADC
1PPS input consumption:	max 1 mADC
Analog output reaction time:	max 200 ms

### MEMORY

System memory:	128 MB Flash, 256 MB RAM
Recording memory:	4 GB (16 GB optional)

### COMMUNICATION

Ethernet ports:	2 Auto MDIX RJ45 10/100 Base Ethernet
GPS port:	1 RS485 optoisolated, 9600 bps
GPS antenna (on PQMGPS1 module):	Active patch antenna, SMA connector
Protocols:	HTTP, HTTPS, FTP, SFTP, NTP, NMEA, Modbus TCP
Integrated router:	GPRS/UMTS-3G/HSPA

### RTC SYNCHRONISATION

Synchronisation system:	NTP and/or GPS
-------------------------	----------------

### ENVIRONMENTAL CONDITIONS

Installation and use code:	PQI-A-FI1
Operating temperature (limit range):	FI1, 3K6 -25 ... +55°C
Storage temperature:	-25 ... +75°C
Relative humidity:	95% max without condensing
Altitude:	max 2000 m AMSL

### MECHANICAL CHARACTERISTICS

Mounting:	Rack 19" 3U
Size:	Front (LxH): 482.6x133.35mm, Rear (LxHxD): 380x128x215 mm
Weight:	4000 g

### STANDARDS

Product compliance:	IEC/EN 62586-1, IEC/EN 62586-2
Certification:	Class A, IEC/EN 61000-4-30:2015 Ed.3 for voltage
Safety:	CAT III power supply, insulation class 2, 600 V
Directive:	2006/95/EC LV, EN 61010
EMC:	2004/108/EC EMC, EN 50081-2, EN 50082-2, EN 61326/A1, EN 55011:1998+A1:1999+A2:2002, EN 61000-6-2/-4-2/-4-3/-4-4/-4-5/-4-6/-4-11

## » 15 Digit Order Code

PQM3000RGW



### Labelling

A = Algodue  
C = Custom (instrument name, label, manual, web server)



### Quick guide language

U = English/Italian  
I = Italian/English  
D = German/English  
F = French/English  
E = Spanish/English



### Power supply

A = 85...285 VAC / 65...250 VDC  
R = 19...60 VDC

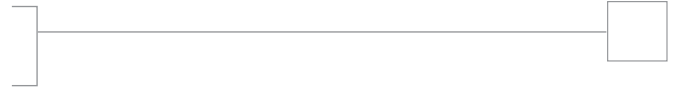

### Rogowski coil length

3 = No. 5 MFC150 30 cm (internal Ø~10 cm), 3 m cable  
4 = No. 5 MFC150 45 cm (internal Ø~14 cm), 3 m cable  
7 = No. 5 MFC150 70 cm (internal Ø~22 cm), 3 m cable  
9 = No. 5 MFC150 90 cm (internal Ø~29 cm), 3 m cable



### Communication ports

R = 2 Ethernet, 1 router



### GPS for synchronisation

E = External PQMGPS1 module



X

X

### Recording memory

4 = 4 GB  
6 = 16 GB



X

X

### Inputs & Outputs

B = 11 digital inputs, 4 analog outputs



## » Default Configurations

### LEGEND:

**RGW**=instrument with current inputs for Rogowski coils (5 MFC150 Rogowski coils included)

**GPS for synchro**=external GPS module (PQMGPS1) for RTC synchronisation, provided with the instrument

**DI**=11 digital inputs

**AO**=4 analog outputs

DEFAULT CONFIGURATION	ORDER CODE	NO. 5 MFC150 INCLUDED		COMMUNICATION		GPS FOR SYNCHRO	RECORDING MEMORY		I/O	
		Length [cm]	Ø [cm]	ETHERNET	ROUTER	External with PQMGPS1	4 GB	16 GB	DI	AO
PQM3000RGW 4GB KIT30	AQQAU3REXX4XXB	30	~10	●	●	●	●		●	●
PQM3000RGW 4GB KIT45	AQQAU4REXX4XXB	45	~14	●	●	●	●		●	●
PQM3000RGW 4GB KIT70	AQQAU7REXX4XXB	70	~22	●	●	●	●		●	●
PQM3000RGW 4GB KIT90	AQQAU9REXX4XXB	90	~29	●	●	●	●		●	●
PQM3000RGW 16GB KIT30	AQQAU3REXX6XXB	30	~10	●	●	●		●	●	●
PQM3000RGW 16GB KIT45	AQQAU4REXX6XXB	45	~14	●	●	●		●	●	●
PQM3000RGW 16GB KIT70	AQQAU7REXX6XXB	70	~22	●	●	●		●	●	●
PQM3000RGW 16GB KIT90	AQQAU9REXX6XXB	90	~29	●	●	●		●	●	●

Other order codes on request (MOQ 30 pcs)

### NOTE:

- Subject to change without notice

- The code made up of 15 digits including the X



**algodue**<sup>®</sup>  
ELETTRONICA

Innovative Electronic Systems

Via Passerina, 3/A - 28010 Fontaneto d'Agogna (NO) - Italy - Tel.: +39 0322 89307 • Fax: +39 0322 89871

sales@algodue.it - [www.algodue.com](http://www.algodue.com)

72PG01\_2\_201601\_5