

SIN-8

- ▣ binary inputs module
- ▣ 8 independent voltage inputs
- ▣ RS-485 / Modbus RTU
- ▣ LEDs for module operation and Modbus transmission signalling



Module type **SIN-8** allows to monitor 8 binary voltage inputs via the RS-485 connection. It finds application in distributed control and visualization systems.

Standard Modbus protocol transmission functions make device registers (address, state of inputs, device ID). All **SIN-8** operating functions, available via the RS-485, can be implemented with any typical visualization software or, for instance, with a suitably **MultiCon CMC** controller. Registers state actualisation occurs only if input signal have fulfil some time restrictions. These restrictions depend on settings of internal digital filter implemented in firmware. Filter allows to eliminate signal oscillations corresponding to contacts bouncing (of mechanical sensors). Filter is factory switched off.

- galvanic separation of the digital inputs from the module supply voltages,
- internal digital filter,
- signalling of inputs logic status and RS-485,
- signalling MODBUS correct operation and transmission,
- input signals connected by means of the socket-plug connectors.

Connection terminals

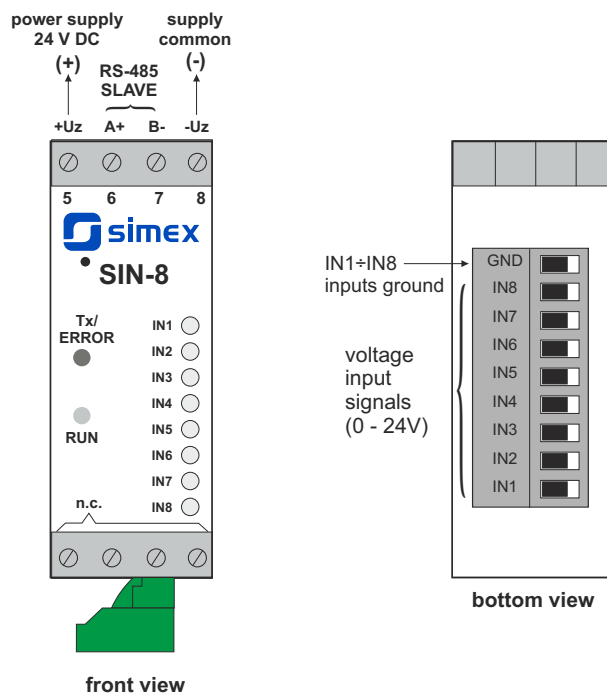

Connection and principle of operation

Connect the supply voltage to the module (+Uz, -Uz, typically 24V DC) and two wires RS-485 (A+, B-) communication interface. Voltage Inputs are placed on bottom side of the module (look: bottom view). Directly after power on the device is signalling its normal operation flashing green LED, marked „RUN” (about 2 times/sec.). Short flashes of LED marked “TX/ERROR” signalize activity of RS-485 interface (data flow between module and Master device) and permanent light of this LED means malfunction of the device. Green LEDs marked “IN1” - “IN8” signalize active state on particular binary inputs (logic HIGH state). When particular input is in active state then corresponding register value is 01h, otherwise its value is 00h.

Ordering

SIN-8-XX1

options:

- 00 : no options
- 08 : operating temp. -20°C ÷ +50°C

Technical data

- Power supply voltage:** 24V DC typically
- Maximum supply voltage fluctuations:** from +16V DC to +30V DC
- Required external fuse:** T - type, max. 1 A
- Current consumption:** 20 mA typical
- Number of independent inputs:** 8 binary
- Input levels:** LOW state: 0V (0 ÷ 3V)
HIGH state: 24V (15 ÷ 24V)
- Galvanic separation:** all 8 inputs are galvanically isolated from module supply and RS-485 interface
- Communication interface:** RS-485, 8N1
- Transmission protocol:** Modbus RTU
- Baud rate:** 1200 ÷ 115200 bit/sec.
- Number of modules in a single network:** max. 128
- Data memory:** non-volatile memory, EEPROM type
- Operating temperature:** 0°C ÷ +50°C (standard), -20°C ÷ +50°C (option)
- Storage temperature:** -10°C ÷ +70°C (standard), -20°C ÷ +70°C (with option 08)
- Humidity:** max. 90%, non-condensing
- Protection class:** IP 20 (housing and connection clips)
- Installation method:** on the 35 mm strip
- Case dimensions:** 101 x 22,5 x 80 mm