

PQM4000

Class A DIN 192x144 power quality analyzer for CTs or current clamps

- Two different models, for CTs or current clamps
- Harmonics and interharmonics measurement
- Data recording for further EN 50160 analysis
- Data recorded in standard PQDIF and CSV file formats
- Embedded web server
- Communication on Ethernet, RS485 and WIFI
- USB host port for data transfer
- Integrated GPS for accurate timing
- High resolution TFT display with capacitive touch
- Internal rechargeable backup battery
- Certified according to **IEC/EN 61000-4-30:2015 Ed.3**, Class A for voltage characteristics



» General features

PQM4000 is a high-end power quality analyzer, able to monitor and record the major power quality parameters. It provides an accurate measurement, voltage characteristics are monitored according to Class A specification. At the same time it acts as event/fault recorder, capable to store a high number of voltage events and disturbances, frequency variations, inrush current, etc. Additional PQ data can be recorded, such as Flicker, Unbalance, Harmonics and Interharmonics, Mains Signalling. It also provides standard power measurement data for three-phase systems. Extra voltage and current measurement channels give the possibility to monitor Neutral Potential and Earth Leakage current.

PQM4000 is available in 2 models: one for external standard CTs with 1 or 5A output and another one for current clamps with 1 or 3V output. In this way maximum flexibility is granted even on existing plants.

The powerful recording features give the possibility to capture and record all types of standard and PQ data simultaneously. All this information can be recorded for long time period due to the high memory capacity, in this way a complete EN 50160 analysis can be performed. Events and disturbances provide also waveform recording together with RMS values. Recordings can be transferred in different ways: user can download them directly through web interface or set an automatic scheduled data upload to a remote server or transfer it to an USB flash drive.

PQM4000 includes different communication ports so the user can access it in different ways. The Ethernet ports on the front and rear panels allow complete control on the instrument: web access for real-time monitor, device setup, stored data transfer, maintenance operations. An additional RS485 port gives the possibility to interconnect the device with slower monitoring systems, such as PLC. The integrated GPS receiver provides accurate time information regardless of the location where the meter is installed in a distributed monitoring system.

Moreover, different I/O channels are provided to enhance the instrument features. It is provided with a high resolution TFT display with touch screen which allows a fast and direct instrument management. User-friendly multilingual interface is common to its web server, very useful for on-site instrument operations.

» Benefits

- Additional voltage and current measurement channels in comparison with other standard three-phase devices.
- Current inputs for CTs or for clamps to grant an accurate current measurement.
- Continuous monitoring of the power quality and Class A certified measurements for voltage characteristics.
- Simultaneous recording of events, Min/Avg/Max LOG and energy counters.
- Several possibilities for instrument data transmission: Ethernet, WIFI, Modbus RTU/TCP, USB.
- User-friendly instrument web interface with multilingual pages.

» Applications

- Power monitoring & control systems
- Switchboards, gensets, motor control centers, etc.
- Individual machine load monitoring
- Power demand analysis and management
- Harmonics monitoring
- Remote metering and cost allocation
- Motor inrush current studies

» Related products

- *PQM-Tool* Class A monitoring software tool
- *PQM-Analyzer* for data analysis according EN 50160

» Main features

Measurements

- Voltage direct connection up to 1000 VLL or through PT for MV and HV systems.
- 4th voltage channel for measurement of potential difference between Neutral and Protective Earth.
- 5 current channels to be used with CTs or clamps according to the model.
- 4th current channel dedicated for Neutral current measurement, for both models the current measuring range (CT primary and secondary, clamp full scale and voltage output) can be programmed together with the main three-phase channels.
- 5th current channel reserved for Earth Leakage monitoring, with separate current measuring range setup to ensure different sensitivity from the main channels.
- Three-phase 3 and 4 wire or single-phase operating mode.
- Suitable for 50 and 60 Hz systems.
- Fast simultaneous sampling on all 9 channels, at 1024 samples/cycle.
- All measured voltage characteristics certified according to IEC/EN 61000-4-30:2015 Ed.3, Class A.
- Measurement of additional power quality parameters, such as K Factor.

Recordings & data storage

- Voltage event recording (sags, swells, interruptions) with storage of ½c RMS values and waveforms.
- Sag/swell recording on 4th voltage channel with storage of ½c RMS values and waveforms.
- Rapid Voltage Changes measurement and event recording.
- Power frequency variation monitoring and recording with ½c RMS values and waveforms.
- "Slow" event recording on Frequency, Unbalance Ratio, Flicker, Voltage THD and Mains Signalling variations.
- Overcurrent recording on three-phase current channels with storage of ½c RMS values and waveforms.
- Data LOG function for Min/Avg/Max values of selectable parameters, at programmable rate.
- Energy counter LOG at programmable rate.
- Functional event LOG to report the changes of device operating status, useful to keep the instrument condition under control.
- Digital input status change LOG.
- Automatic data upload to FTP server started by frequency events or scheduled at preset time day by day.
- Recordings containing big amount of data ½c RMS with waveform and Min/Avg/Max are recorded directly in standard PQDIF files.
- For other type of recordings, "slow" events, Energy LOG, Functional LOG, Digital input LOG, data is provided in standard CSV files.
- In case of a failure on the PQM auxiliary power line, the monitoring and recording functions remains active due to the backup battery.

Inputs & outputs

- 4 isolated digital inputs for remote management of control signals.
- 4 isolated digital outputs for alarm signalling or energy pulse generation.
- 4 isolated analog outputs for real time parameter variation transmission.

Communication

- Two Ethernet ports, one designed for a permanent installation on the instrument rear and one for occasional connections on the front panel.
- RS485 port for data reading in Modbus RTU.
- WIFI port, programmable in different modes: as Access Point to take advantage of the broadcasted WIFI network or as Client mode for a standard WIFI connection.
- Front USB host port useful to transfer in a simple way data recorded from the instrument to an external device, but also to save setup or to upgrade instrument firmware.

Data analysis

- Standard file formats gives the possibility to have a quick view and analysis on all stored data without any special software.
- PQM-Analyzer software is provided to perform statistical analysis and generate reports on recorded data according to EN 50160 PQ standard.

» Technical drawing (mm)

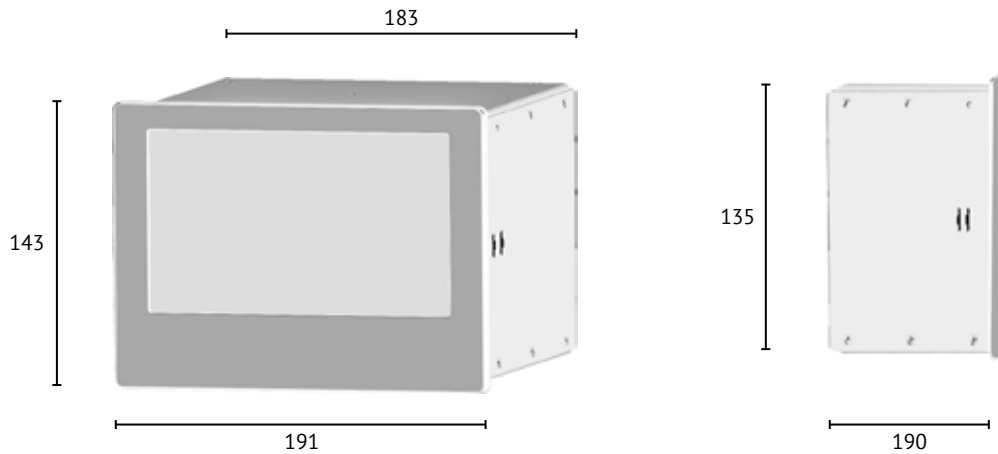

» Parameters overview

PARAMETER GROUP	LIST	MEASURE	EVENT	LOG	OUTPUTS
Voltages	ULN, ULL, U4N, U4L, U Σ	●	●	●	●
Currents	IL, IN, IEL, I Σ	●	●	●	●
Powers	PL- Σ , QL- Σ , SL- Σ	●		●	●
Power Factors	TPFL- Σ , DPFL	●		●	●
Frequency	F	●	●	●	●
Phase Order	-	●			
Volt Symmetrical Components	U0, U1, U2	●		●	●
Volt Unbalance Ratios	u0, u2	●	●	●	
Volt Deviations (under, over)	ULN, ULL	●			●
Flickers	PinstL, PstL, PltL	●	●	●	
Harmonics up to 50th & Interharmonics	ULN, ULL, IL, PL, QL	●		●	●
Total Harmonic Distortions and K Factors	ULN, ULL, IL, KL	●	●	●	●
Mains Signallings	5 x ULN	●			
Phase Angles	U-U, U-I	●			●
Energy Counters (4Q)	active, reactive, app. Σ	●		■	●
Rapid Voltage Changes	ULN		●		
Flagging	Sag, Swell, Interruption			●	
Aggregated values	Voltage characteristics	●			
Waveforms	ULN, ULL, IL	●	●		
Mean values	ULN, F, Flicker, Unbal, THDU	□	●		

NOTES:

- Some of the parameters are not available for all functions, for more details refer to the user manual.
- LOG function means Min/Avg/Max recording, except for Energy counters (■).
- Parameters in MEASURE column can be displayed or read by communication port, except for Mean values (□).

» Specifications

POWER SUPPLY

Auxiliary power voltage:	85...285 VAC 50/60 Hz / 65...250 VDC
Auxiliary power consumption:	15 VA max
Fuse:	250 VAC / 500 mA T type delayed
Backup battery:	Li-Ion, 2500 mAh (>15 min autonomy)

MEASUREMENT INPUTS

Three-phase voltage inputs for direct connection / PT:	P-N: max 580 V RMS CAT III, L-L: max 1000 V RMS CAT III
U4 voltage input for direct connection:	max 580 V RMS CAT III
Voltage input crest factor:	2
Voltage input impedance:	>2 MΩ/phase
CT model - CT secondary:	selectable 1A, 5A RMS
CT model - maximum current:	7A RMS
CT model - CT input burden:	0.04 VA
Clamp model - clamp output full scale:	selectable 1V, 3V RMS
Both models - crest factor:	3
Frequency range:	42.5...57.5 Hz / 51...69 Hz
Frequency reference channel:	Phase 1/Line 12 voltage
Sampling:	Simultaneous, 51.2 kHz @50 Hz

ACCURACY

Three-phase voltage:	±0.1% Un over 10 ... 150% Un range
U4 voltage:	±0.2% measurement
Currents:	±0.2% measurement (device)
Powers:	±0.2% measurement
Frequency:	±8 mHz
Harmonics:	Class 1 (IEC/EN 61000-4-7)
Realtime clock (RTC):	<1s in 24h without synchronisation; <5ms with GPS synchronisation
Active energy:	Class 0.5S, compliant to IEC/EN 62053-22
Reactive energy:	Class 1, compliant to IEC/EN 62053-23

I/O CHANNELS

Digital inputs:	4 optoisolated, 24 VDC ±20%
Digital outputs:	4 passive optoisolated (PhotoMOS), 24 VDC-50 mA
Analog outputs:	4 optoisolated, 4 ... 20 mADC, max load 500 Ω
Digital input delay time:	max 10 ms
Digital input consumption:	max 7 mADC
Digital output delay time:	In alarm mode, max. 200 ms
Digital output pulse time:	In pulse mode, 50 ms±2
Analog output reaction time:	max 200 ms

MEMORY

System memory:	128 MB Flash, 256 MB RAM
Recording memory:	4 GB (16 GB optional)

COMMUNICATION

Ethernet ports:	2 Auto MDIX RJ45 10/100 Base Ethernet
RS485 port (slave):	Optoisolated, 0.5UL, 2400...115200bps
WIFI antenna:	Passive antenna, SMA connector on rear panel
GPS antenna:	Active patch antenna, remote powered, SMA connector
Protocols:	HTTP, HTTPS, FTP, SFTP, NTP, NMEA, Modbus TCP, Modbus RTU
USB port:	USB 2.0 A type socket, high speed 480 Mbit/s

RTC SYNCHRONISATION

Synchronisation system:	NTP and/or GPS
-------------------------	----------------

ENVIRONMENTAL CONDITIONS

Installation and use code:	PQI-A-FI1
Operating temperature (limit range):	FI1, 3K6 -25 ... +55°C
Storage temperature:	-25 ... +75°C
Relative humidity:	95% max without condensing
Altitude:	max 2000 m AMSL

MECHANICAL CHARACTERISTICS

Mounting:	Panel mount 192x144 DIN size
Size:	Front (LxH): 191x143 mm, Rear (LxHxD): 183x135x190 mm
Weight:	1400 g

STANDARDS

Product compliance:	IEC/EN 62586-1, IEC/EN 62586-2
Certification:	Class A, IEC/EN 61000-4-30:2015 Ed.3 for voltage
Safety:	CAT III power supply, insulation class 2, 600 V
Directive:	2006/95/EC LV, EN 61010
EMC:	2004/108/EC EMC, EN 50081-2, EN 50082-2, EN 61326/A1, EN 55011:1998+A1:1999+A2:2002, EN 61000-6-2/-4-2/-4-3/-4-4/-4-5/-4-6/-4-11

» 15 Digit Order Code

PQM4000

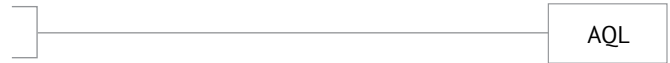

Labelling

A = Algodue
C = Custom (instrument name, label, manual, web server)



Quick guide language

U = English/Italian
I = Italian/English
D = German/English
F = French/English
E = Spanish/English



Power supply

A = 85...285 VAC / 65...250 VDC
R = 19...60 VDC

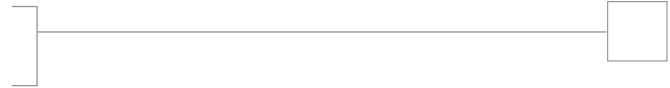

Current input model

6 = For CTs
C = For current clamps



Communication ports

W = 2 Ethernet, 1 RS485, 1 WIFI, 1 USB



GPS for synchronisation

I = Integrated



X

X

Recording memory

4 = 4 GB
6 = 16 GB



X

X

Inputs & Outputs

A = 4 digital inputs, 4 digital outputs, 4 analog outputs



» Default Configurations

LEGEND:

CT=instrument with current inputs for CTs (CTs NOT included)

Clamp=instrument with current inputs for clamps (clamps NOT included)

GPS for synchro=GPS module for RTC synchronisation, integrated in the instrument

DI=4 digital inputs

DO=4 digital outputs

AO=4 analog outputs

DEFAULT CONFIGURATION	ORDER CODE	CURRENT INPUT MODEL		COMMUNICATION				GPS FOR SYNCHRO	RECORDING MEMORY		I/O		
		For CTs	For Clamps	ETHERNET	RS485 read-only	WIFI	USB	Integrated	4GB	16GB	DI	DO	AO
PQM4000 4GB CT	AQLAUA6WIXX4XXA	●		●	●	●	●	●	●		●	●	●
PQM4000 4GB Clamp	AQLAUACWIXX4XXA		●	●	●	●	●	●	●		●	●	●
PQM4000 16GB CT	AQLAUA6WIXX6XXA	●		●	●	●	●	●		●	●	●	●
PQM4000 16GB Clamp	AQLAUACWIXX6XXA		●	●	●	●	●	●		●	●	●	●

Other order codes on request (MOQ 30 pcs)

NOTE:

- Subject to change without notice

- The code made up of 15 digits including the X



algodue®
ELETTRONICA

Innovative Electronic Systems

Via Passerina, 3/A - 28010 Fontaneto d'Agogna (NO) - Italy - Tel.: +39 0322 89307 • Fax: +39 0322 89871

sales@algodue.it - www.algodue.com

72PG01_2_201601_5