

DT9837 Series

High Performance, USB Powered Modules for Sound & Vibration Analysis

The DT9837 Series high accuracy dynamic signal acquisition modules are ideal for portable noise, vibration, and acoustic measurements. Four, 24-bit, IEPE (ICP®) sensor inputs are synchronized with a tachometer input (depending on model selected) to provide data streams that are matched in time, for field and laboratory use. These rugged, compact modules are USB powered, making them ideal for portable measurement applications.

Key Features:

- Runs on USB Power...ideal for portable applications
- Four Simultaneous, 24-bit Delta-Sigma A/D converters for high resolution measurements
- Support for IEPE (Integrated Electronic Piezoelectric) inputs, including use of a 4 mA current source and AC or DC coupling
- Up to 105.4 kHz sampling rate per channel
- Input range of ± 10 V with software-selectable gains of 1 and 10 for an effective input range of ± 10 V and ± 1 V
- For DT9837C modules only, 1 Hz high-pass filter on analog input subsystem
- Return the value of tachometer counter 0 in the analog input data stream, to measure the period or frequency of the tachometer input signal synchronously with analog input measurements
- For the DT9837A and DT9837B modules only, the ability to read the value of tachometer counter 1 in the analog input data stream, allowing you to precisely correlate tachometer measurements with analog input measurements
- For the DT9837A-OEM and DT9837B modules only, the ability to read the value of gate counter 2 in the analog input data stream, allowing you to precisely correlate gate input measurements with analog input measurements
- For the DT9837A modules only, support for reading analog output values in the analog input data stream, allowing you to correlate input and output values
- Start trigger for acquiring pre-trigger samples and a reference trigger for acquiring post-trigger samples. Specify the number of post-trigger samples to acquire before stopping the operation.
 - Start trigger supports a software-programmable trigger source (software, external digital trigger, or a positive-going analog threshold trigger on analog input channel 0). The threshold level is fixed at 1.0 V for the analog threshold trigger.

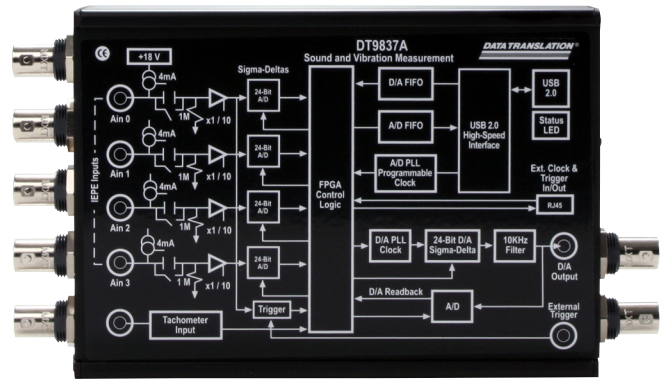

Figure 1. The DT9837A has 4 simultaneous IEPE sensor inputs plus a synchronous tachometer input and is ideal for portable noise and vibration measurement applications.

- Reference trigger supports a positive- or negative-going analog threshold trigger on any of the analog input channels. You can program the threshold value from -10 V to $+10$ V.
- Internal clock source (shared between the analog input and analog output subsystems)
- For the DT9837A, DT9837B, and DT9837C modules only, RJ45 synchronization (LVDS) connector for synchronizing acquisition on up to four modules
- BNC connectors for all models, Mini-XLR connectors available on DT9837C for audio inputs

Analog output subsystem (DT9837):

- One 24-bit D/A converter
- Waveform capability of up to 8,192 sample
- Output rate of 46.875 kSamples/s
- Output range of ± 10 V
- A software trigger starts the analog output operation

Analog output subsystem DT9837A):

- One 24-bit D/A converter
- Single value, waveform, and continuous streaming output
- Programmable output rate from 10 kSamples/s to 52.734 kSamples/s
- Output range of ± 10 V
- Software-programmable trigger source (software trigger, external digital trigger, or analog threshold trigger) to start the analog output operation.

Analog output subsystem (DT9837C):

- One 24-bit D/A converter
- Single value, waveform, and continuous streaming output
- Programmable output rate from 10 kSamples/s to 96 kSamples/s
- Output range of ± 3 V
- ± 2 mA output current
- Software-programmable trigger type (software trigger, external digital trigger, or analog threshold trigger) to start the analog output operation.

	DT9837	DT9837A	DT9837B	DT9837C
Analog Input Features				
4, single-ended, simultaneous channels	•	•	•	•
24-bit Resolution	•	•	•	•
High-Pass Filter	0.5 Hz	0.1 Hz	0.5 Hz	1 Hz
AC/DC Coupling	•	•	•	•
Current Source	4 mA	4 mA	4 mA	2 mA
Max Sampling Rate/Ch	Up to 52.7 kHz	Up to 52.7 kHz	Up to 105.4 kHz	Up to 105.4 kHz
A/D Threshold Trigger	Fixed	Programmable	Programmable	Programmable
1 Tachometer	•	•	•	•
±30V Tachometer Input Range	•	•	•	•
Gate Input*		•	•	•
Synchronized with AO	•	•	•	
Analog Output Readback Capability				
Analog Output Features				
1 Channel	• Single Value	• Waveform Streaming		• Waveform Streaming
24-bit Resolution	•	•		•
Max Sampling Rate	46.875 kHz (fixed)	Up to 52.7 kHz		96 kHz
Streaming Mode		•		•
Buffer Mode	•	•		•
Synchronized with AI		•		
Trigger Types	Software trigger only	Software trigger, external digital trigger, or analog threshold trigger		Software trigger, external digital trigger, or analog threshold trigger
Other Features				
Multiple Module Synchronization		•	•	•
Connectors	BNC	BNC	BNC	BNC or mini XLR

*Available on the DT9837A-OEM version. Available through BNC connector on the DT9837B module.

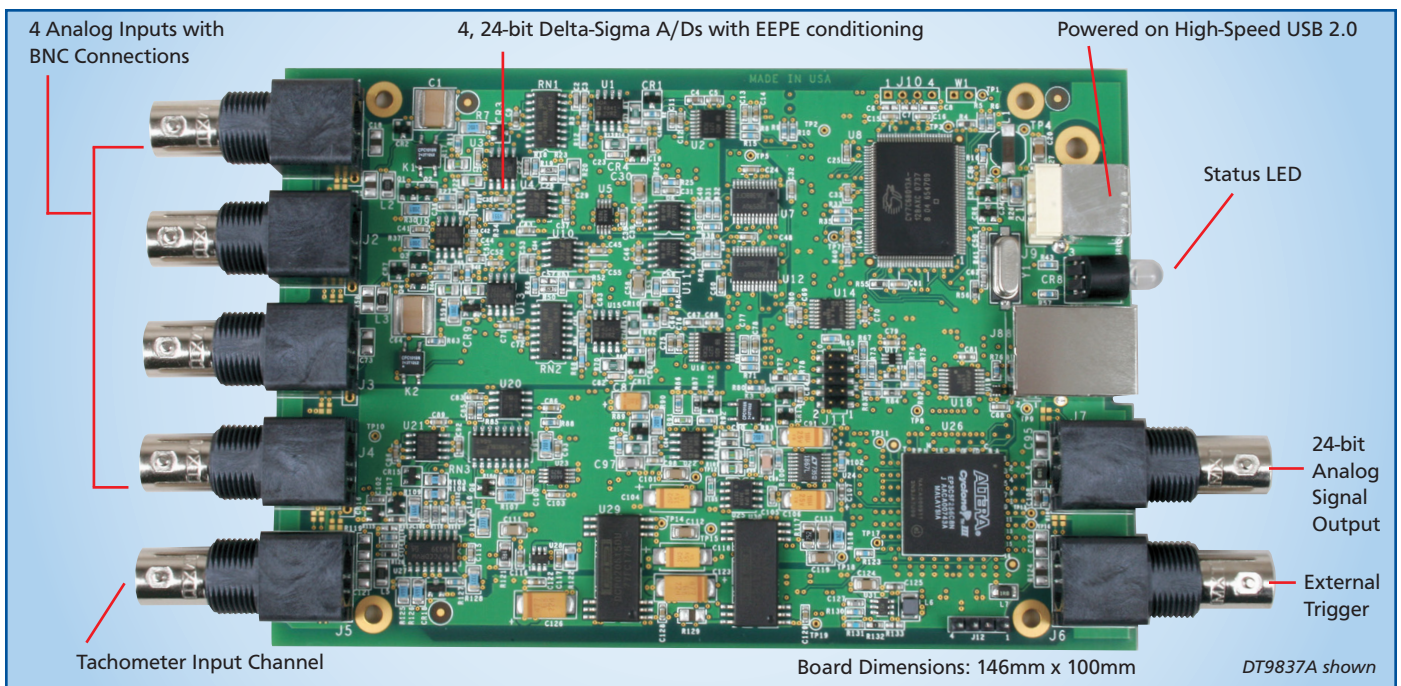

Figure 2. A board-level version of the DT9837A is available (DT9837A-OEM). These modules provide BNC connectors for easy signal connections. The DT9837A-OEM provides an additional gate input connector for precisely correlating analog input and gate input measurements.

DT9837 Block Diagram

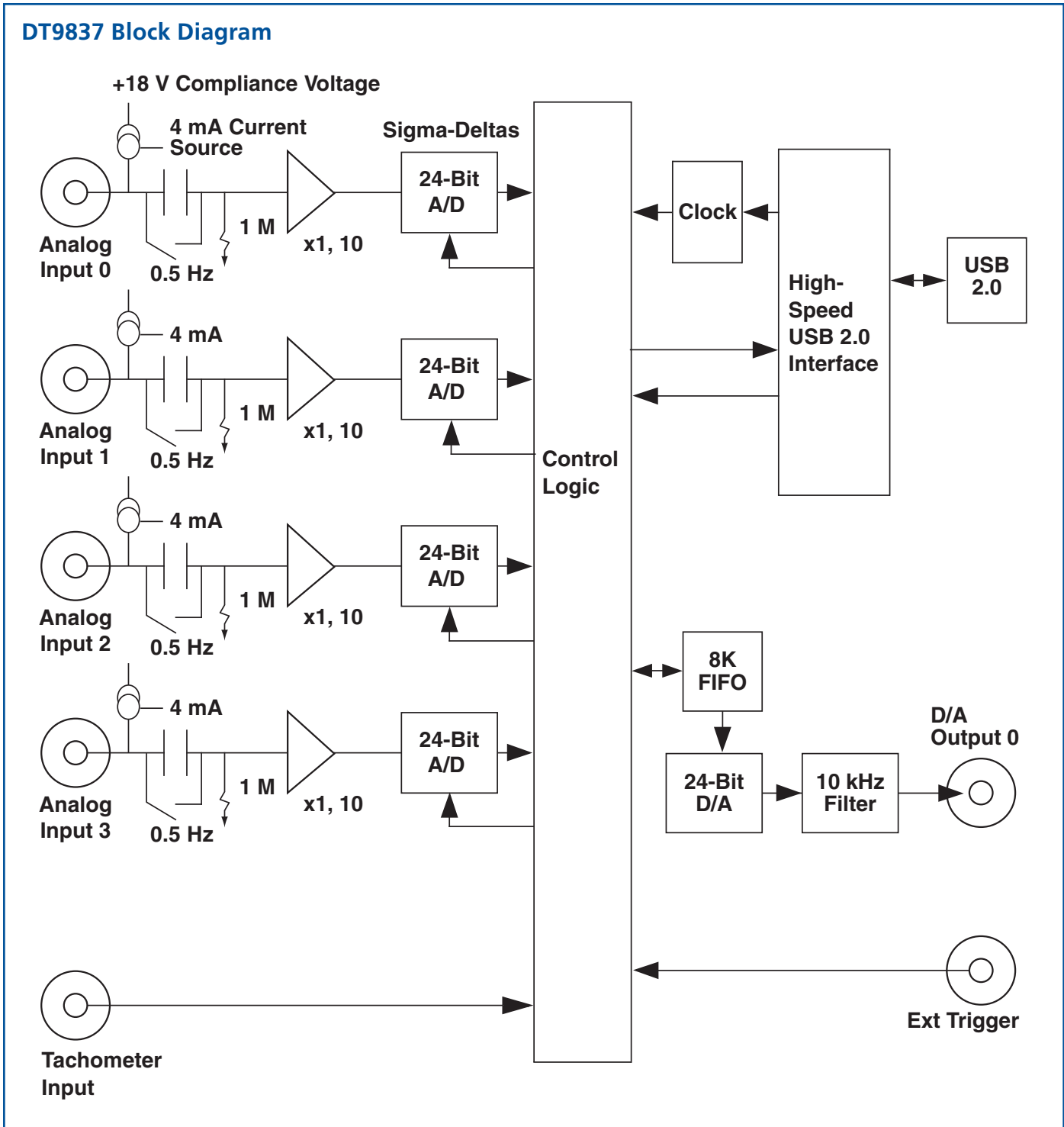

Figure 3. DT9837 Block Diagram

DT9837A Block Diagram

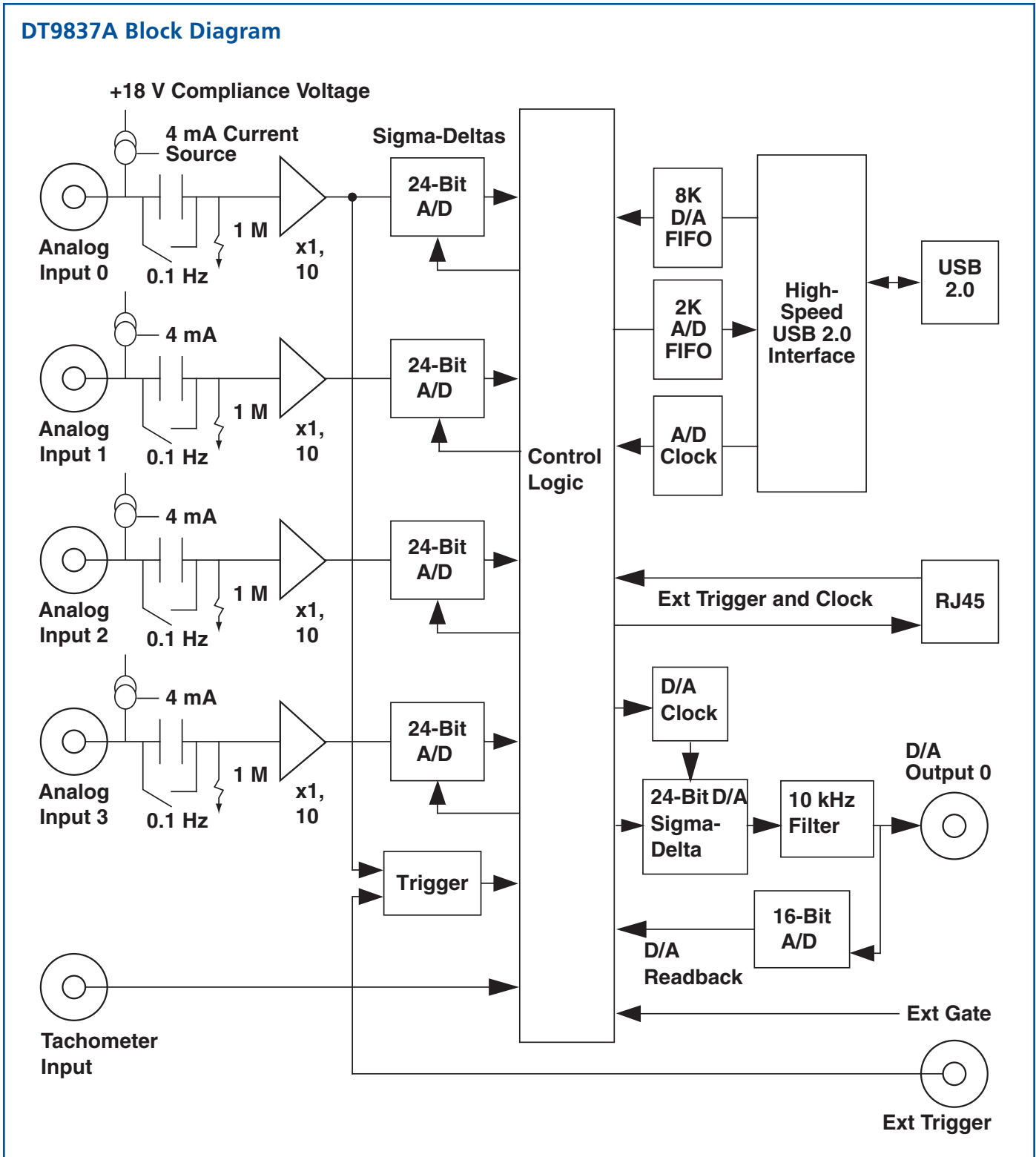

Figure 4. DT9837A Block Diagram

DT9837B Block Diagram

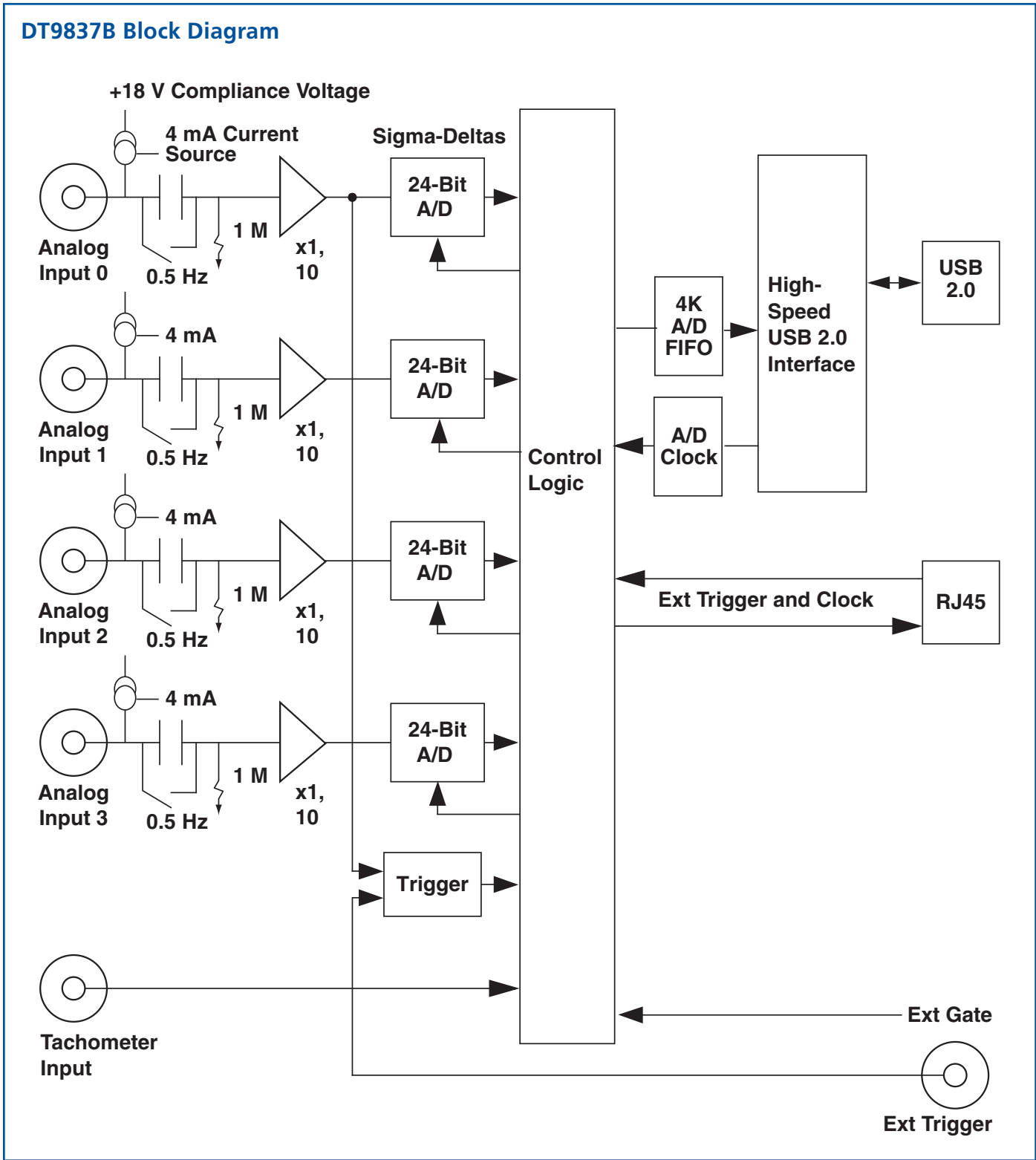

Figure 5. DT9837B Block Diagram

DT9837C Block Diagram

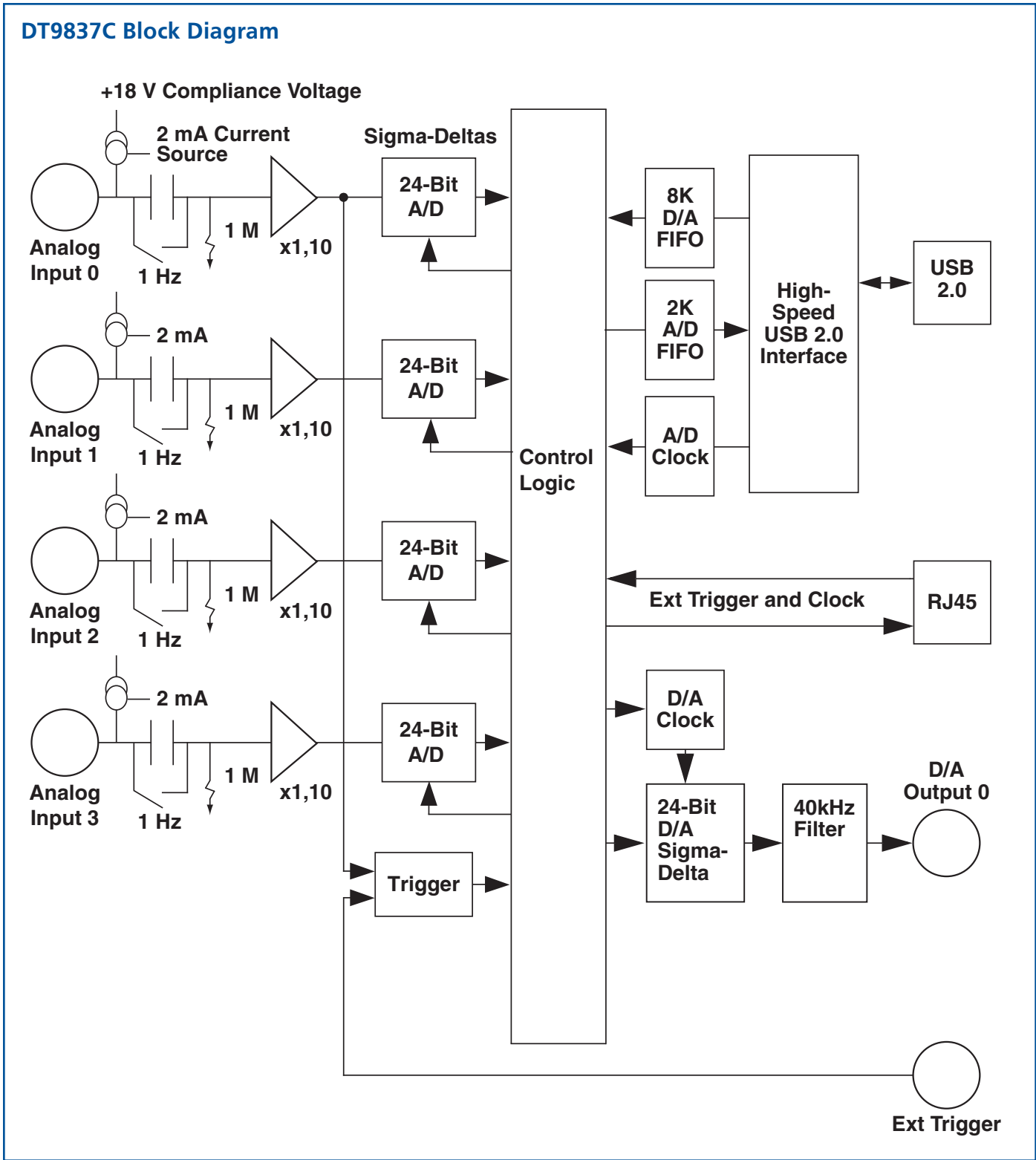

Figure 6. DT9837B Block Diagram

Analog Input Channels

The DT9837 Series modules support four, single-ended analog input channels. All analog input channels are simultaneously clocked. Software-selectable gains of 1 and 10 provide effective input ranges of ± 10 V and ± 1 V. The DT9837 Series modules use 24-bit Delta-Sigma analog-to-digital converters (ADCs) that provide anti-aliasing filters based on the clock rate. These filters remove aliasing, which is a condition where high frequency input components erroneously appear as lower frequencies after sampling.

DT9837 Series modules can acquire a single value from a single analog input channel, a single value from all the analog input channels simultaneously, or multiple values from a group of analog input channels. Depending on the module, the following channels may also be read tachometer input, gate input, and analog output readback channel.

IEPE Functions

Applications that require accelerometer, vibration, noise, or sonar measurements often use IEPE sensors. IEPE conditioning is built-in to the analog input circuitry of the DT9837 Series modules. The modules support the following software-programmable IEPE functions for each of the four analog inputs:

- **Excitation current source** – The DT9837, DT9837A, and DT9837B modules provide an internal excitation current source of 4 mA. The DT9837C module provides an internal excitation current source of 2 mA.
- **Coupling type** – Select whether AC coupling or DC coupling is used.

The DT9837C also provides a 1 Hz high-pass filter.

Programmable A/D Clock

The DT9837 Series modules support an internal clock, which is derived from the USB clock. Use software to specify the internal clock source and the frequency at which to pace the input and output operations and to start the sample clock. For the DT9837 and DT9837A, the sampling frequency ranges from 195.3 Hz to 52.734 kHz. For the DT9837B and DT9837C, the sampling frequency ranges from 195.3 Hz to 105.469 kHz.

Note: According to sampling theory (Nyquist Theorem), specify a frequency that is at least twice as fast as the input's highest frequency component. For example, to accurately sample a 20 kHz signal, specify a sampling frequency of at least 40 kHz to avoid aliasing. The modules support a wide pass band of 0.5 Hz (0.1 Hz for the DT9837A) to 25.8 kHz (0.49 x sampling frequency) to eliminate aliasing, allowing you to measure low frequency signals accurately at the Nyquist sampling rate. The actual frequency that the module can achieve may be slightly different than the frequency specified due to the accuracy of the clock. The actual clock frequency can be determined using software.

Internally, the value specified for the internal clock frequency is multiplied by 512 (for frequencies of 52.734 kHz or less) or 256 (for frequencies greater than 52.734 kHz) to set the oscillator on the module.

Once the sample clock is started, the module requires 39 clock pulses before the first A/D conversion is completed (39/sample rate) due to the group delay of the converters. The software automatically adjusts for the group delay to provide only valid data in each buffer.

The tachometer data (which does not have the 39 sample group delay) is synchronized with the analog data stream. This is done through the firmware and device driver by caching the tachometer data and aligning it in time with the analog data in the user's data buffers.

Analog Input Conversion Modes

DT9837 Series modules support single-value, single-values, and continuous scan conversion modes:

- **Single-Value Operations** – Specify the analog input channel (0, 1, 2, or 3) and the gain to be used. The module acquires the data from the specified channel and returns the data immediately.
- **Single-Values Operations** – Use a single-values operation to read a single value from all the analog input channels simultaneously using one software call. Specify the analog input subsystem and the gain for the channels (not the channels themselves). The module then acquires a value from each input channel simultaneously; the data is returned as an array of input values.
- **Continuous Scan Mode** – Continuous scan mode takes full advantage of the capabilities of the DT9837 Series modules. Specify a channel list, clock source, trigger source, and buffer using software.

When the start trigger is detected, the module simultaneously acquires pre-trigger data from all of the input channels specified in the channel list. The sampled data is placed in the allocated buffer(s). When the reference trigger occurs, pre-trigger data acquisition stops and post-trigger acquisition starts. The operation continues until the number of samples specified for the post-trigger scan count are acquired; at that point, the operation stops. The conversion rate is determined by the frequency of the input sample clock.

Using software, you can stop a scan by performing either an orderly stop or an abrupt stop. In an orderly stop, the module finishes acquiring the current buffer, stops all subsequent acquisition, and transfers the acquired data to host memory; any subsequent triggers are ignored. In an abrupt stop, the module stops acquiring samples immediately; the current buffer is not completely filled, it is returned to the application only partially filled, and any subsequent triggers are ignored.

Input Triggers

A trigger is an event that occurs based on a specified set of conditions. On the DT9837 Series modules, a start trigger source and a reference trigger source can be specified. Pre-trigger acquisition starts when the start trigger event occurs. When the reference trigger occurs, pre-trigger data acquisition stops and post-trigger acquisition starts. Post-trigger acquisition stops when the number of samples specified for the post-trigger scan count has been reached.

Start Trigger Sources

The DT9837 Series modules support the following trigger sources for the start trigger:

- Software trigger – A software trigger event occurs when you start the analog input operation. Using software, specify the start trigger source as a software trigger.
- External digital (TTL) trigger – An external digital (TTL) trigger event occurs when the module detects a rising-edge transition on the signal connected to the Ext Trig BNC connector on the module. Using software, specify the start trigger source as an external, positive digital (TTL) trigger.

Note: On the DT9837A, DT9837B and DT9837C modules, if you configure the synchronization mode as slave, the RJ45 connector accepts trigger and clock signals from the master; you cannot use the Ext Trig BNC connector on the slave module.

- Analog threshold trigger – For the DT9837 module only, the start trigger event occurs when the signal attached to analog input channel 0 rises above 1.0 V (the fixed threshold level). Using software, specify the start trigger source as a positive threshold trigger, and the threshold trigger channel as channel 0.

For the DT9837A, DT9837B, and DT9837C modules, the start trigger event occurs when the signal attached to analog input channel 0 rises above a user-specified threshold value. Using software, specify the start trigger source as a positive threshold trigger, the threshold trigger channel as channel 0, and the threshold level as a value between 0.2 V to 9.8 V.

Note: On the DT9837A, DT9837B, and DT9837C modules, if you configure the synchronization mode as slave, the RJ45 connector accepts trigger and clock signals from the master; you cannot use the analog threshold trigger on the slave module.

Reference Trigger Sources

The DT9837 Series modules support an analog threshold trigger for the reference trigger. The reference trigger event occurs when the signal attached to a specified analog input channels rises above a user-specified threshold value. Using software, specify the following parameters:

- Reference trigger source – Specify a positive (low-to-high transition) threshold trigger to trigger when the signal rises above a threshold level, or a negative (high-to-low transition) threshold trigger to trigger when the signal falls below a threshold level.
- Threshold channel – Specify any one of the analog input channels as the threshold input channel.
- Threshold level – Specify a value between ± 10 V for a gain of 1 or ± 1 V for a gain of 10 as the threshold level.

Tachometer Input Features

The DT9837, DT9837A, and DT9837B modules accept one ± 30 V, 32-bit tachometer input signal. (The DT9837C does not support a tachometer input.) On the DT9837, this signal has a maximum frequency of 380 kHz and a minimum pulse width of 1.3 μ s. On the DT9837A and DT9837B, this signal has a maximum frequency of 1 MHz and a minimum pulse width of 0.4 μ s. The threshold voltage is fixed at ± 2 V with 0.5 V of hysteresis.

You can measure the frequency or period of the tachometer input signal using tachometer counter 0. On the DT9837A and DT9837B modules, you can also measure the phase of the tachometer input signal in relation to the A/D sample using tachometer counter 1.

Frequency or Period Measurements – Tachometer Counter 0

Use frequency or period measurements to calculate the rotation speed for high-level (± 30 V) tachometer input signals. An internal 12 MHz counter (tachometer counter 0) is used for the measurement, yielding a resolution of 83 ns (1/12 MHz).

Read the number of counts between two consecutive starting edges of the tachometer input signal by including channel 4 in the analog input channel list. On the DT9837 module, the starting edge is always rising; on the DT9837A and DT9837B modules, the starting edge is programmable (either rising or falling).

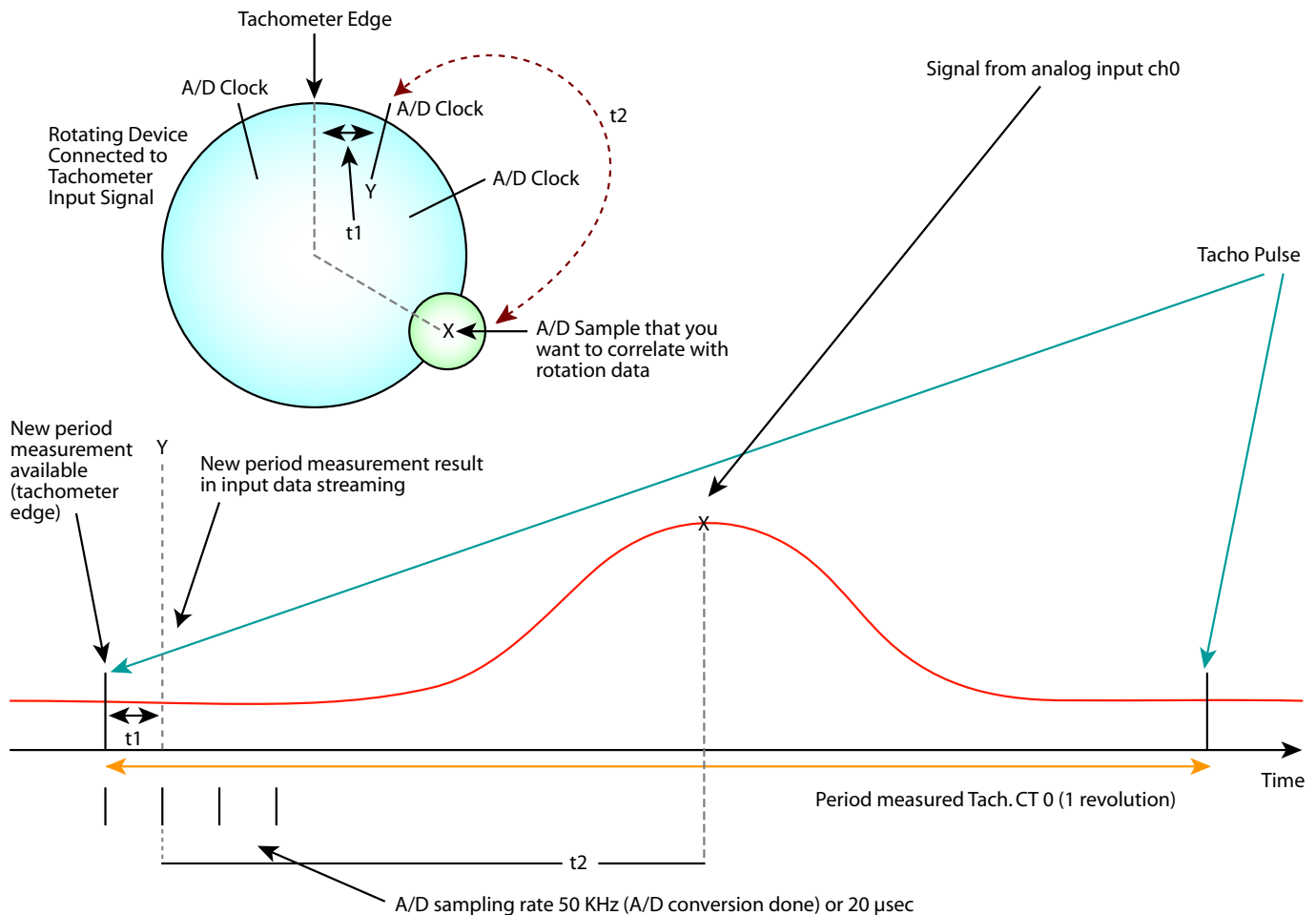

Figure 7. By connecting a rotating device to the tachometer input of the DT9837A, you can measure the frequency or period of the rotating device. The DT9837A also provides the ability to accurately measure the time between the tachometer edge and the next A/D sample or between the A/D sample and the next tachometer edge, so that you can precisely correlate A/D data with rotation data. For example, assume that you want to correlate A/D sample X from analog channel 0 to an angular position of the rotating device. This can be accomplished by using a tachometer signal that always occurs at the top, center position of the rotating device as a reference and measuring the tachometer signal and the next A/D sample (Y). Since you know the frequency of the A/D sample clock (50 kHz, in this case), you know when A/D sample X occurred in relation to A/D sample Y ($t_2 = 1/50\text{kHz} \times \text{num samples from Y to X}$). By using the Tachometer Counter 1 to measure the time (t_1) between the tachometer signal and A/D sample Y, you can calculate exactly where A/D sample X occurred in time from the tachometer signal (result = $t_1 + t_2$). Given the rotation speed of Tachometer Counter 0, you can then calculate the angular position of A/D sample X

Specify the following parameters for tachometer counter 0 using the Open Layers Control Panel applet:

- The starting edge of the tachometer input signal to use for the measurement (rising or falling edge). On the DT9837 module, the starting edge is always the rising edge.
- The value read between measurements (either zero, the default value, or the previous measurement value). On the DT9837 module, this value is always the previous measurement value.
- A flag (called Stale) indicating whether or not the data is new. If the Stale flag is set as Used (the default value), the most significant bit (MSB) of the value is set to 0 to indicate new data; reading the value before the measurement is complete returns an MSB of 1. If the Stale flag is set to Not Used, the MSB is always set to 0. On the DT9837 module, the MSB is always 0 (not used).

When the operation is started, the internal 12 MHz counter starts incrementing when it detects the first starting edge of the tachometer input and stops incrementing when it detects the next starting edge of the tachometer input. When the measurement is complete, the counter/timer remains idle until it is read. On the next read, either 0 or the current value of the tachometer input (from the previous measurement operation) is returned depending on the module and the Control Panel settings, described above, and the next operation is started automatically.

The software automatically synchronizes the value of the tachometer input with the analog input measurements, so that all measurements are correlated in time. The tachometer input is treated like any other channel in the analog input channel list; therefore, all the triggering and conversion modes supported for analog input channels are supported for the tachometer input.

Phase Measurements – Tachometer Counter 1

On the DT9837A and DT9837B modules, measure the phase of the tachometer input in relation to the A/D sample by reading tachometer counter 1. To read the value of this counter, specify channel 5 in the analog input channel list.

An internal 48 MHz clock (with 21 ns resolution) is used to calculate the measurement, which allows you to precisely correlate tachometer measurements with the analog input data.

Specify the following parameters for tachometer counter 1 using the Open Layers Control Panel applet:

- The signal that starts the measurement: A/D sample, rising edge of the tachometer input signal, or falling edge of the tachometer input signal
- The signal that stops the measurement: A/D sample, rising edge of the tachometer input signal, or falling edge of the tachometer input signal

Note: Note that if you choose to start the measurement using the A/D sample, choose a tachometer edge to stop the measurement. Likewise, if you choose to stop the measurement using the A/D sample, choose a tachometer edge to start the measurement.

- The value of the Self-Clear flag, which determines the value that is read between measurements (either 0 or the previous measurement value)

Gate Input Features

The DT9837A-OEM module provides a 4-pin gate input connector for connecting a TTL gate input signal. The DT9837B module provides a BNC connector for connecting a gate input signal.

Read the value of gate counter 2 to measure the time between the following signals:

- Completion of the A/D sample to the rising or falling edge of the gate input signal
- Rising or falling edge of the gate input signal to the rising or falling edge of the gate input signal, which you can use to determine the pulse width of the gate signal
- Rising or falling edge of the gate input signal to the completion of the A/D sample

For these measurements, specify channel 6 in the analog input channel list. An internal 48 MHz clock (with 21 ns resolution) is used for the measurements, which allows you to precisely correlate analog input data with measurements from the gate input signal.

Specify the following parameters for gate counter 2 using the Open Layers Control Panel applet:

- The signal that starts the measurement: A/D sample, gate rising edge, or gate falling edge
- The signal that stops the measurement: A/D sample, gate rising edge, or gate falling edge

Note: If you choose to start the measurement using the A/D sample, choose a gate input edge to stop the measurement. Likewise, if you choose to stop the measurement using the A/D sample, choose a gate input edge to start the measurement.

If you choose the start and stop the measurement using the same gate edge, be aware that the stopping edge does not restart the measurement; the next starting edge will start the next measurement.

- The value of the Self-Clear flag, which determines the value that is read between measurements (either 0 or the previous measurement value)

Analog Output Channels

The DT9837, DT9837A, and DT9837C modules support one 24-bit analog output channel. Note that on the DT9837A module, you can read back the value of the analog output channel through the analog input channel list. The DT9837 and DT9837A modules provide a two-pole, 10 kHz Butterworth filter to prevent noise from interfering with the output signal. The analog output channel powers up to a value of 0 V \pm 10 mV.

The DT9837 and DT9837A can output bipolar output signals in the range of \pm 10 V, with a gain of 1. The DT9837C module can output bipolar output signals in the range of \pm 3 V, with a gain of 1.

The output clock on the DT9837, DT9837A, and DT9837C modules is derived from the USB clock to produce the output clock frequency. On the DT9837 module, the clock frequency is fixed at 46.875 kHz. On the DT9837A module, you can program the clock frequency to value between 10 kHz and 52.734 kHz. On the DT9837C module, you can program the clock frequency to value between 10 kHz and 96.0 kHz. Use software to specify an internal clock source and to specify the clock frequency for the analog output subsystem. Internally, the value that you specify for the analog output clock frequency is multiplied by 512 to set the oscillator on the module. The maximum timebase for the DT9837 is 24 MHz; the maximum timebase for the DT9837A and DT9837C is 27 MHz. Due to the group delay of the Delta-Sigma D/A converter, the DT9837 requires 34 clock pulses, while the DT9837A and DT9837C require 29 clock pulses once the analog output sample clock is started before the first D/A conversion is completed.

Output Conversion Modes

The DT9837, DT9837A, and DT9837C modules support single-value and waveform analog output operations. The DT9837A and DT9837C modules also support continuous analog output operations. The DT9837A also provides the ability to read the value of the analog output channel in the analog input data stream.

Single-Value Mode

Single-value mode is the simplest to use but offers the least flexibility and efficiency. Use software to specify the analog output channel that you want to update, and the value to output from that channel. The value is output from the specified channel immediately. For a single-value operation, you cannot specify a clock source, trigger source, or buffer. Single-value operations stop automatically when finished; you cannot stop a single-value operation.

Note: On the DT9837 module, ensure that no analog input operations are running before performing an analog output operation or an error will be reported.

Waveform Generation Mode

Waveform generation mode is supported on both the DT9837, DT9837A, and DT9837C modules. In this mode, a waveform, which is specified in a single buffer, is output repetitively. On the DT9837, allocate a buffer less than or equal to 8192 samples, and then fill the buffer with the waveform that you want to output. On the DT9837A and DT9837C, allocate a buffer of any size, and then fill the buffer with the waveform that you want to output. When it detects a software trigger, the host computer transfers the entire waveform pattern to the FIFO on the module, and the module starts writing output values to the analog output channel at the specified clock rate. The module recycles the data, allowing you to output the same pattern continuously without any further CPU or USB bus activity. When it reaches the end of the FIFO, the module returns to the first location of the FIFO and continues outputting the data. This process continues indefinitely until you stop it.

Note: On the DT9837, an error will be reported if you specify a buffer with greater than 8192 samples (the size of the FIFO on the module). If you want to output data from the analog output channel on the DT9837 module while acquiring analog input data, ensure that you set up and start the analog output operation before starting the analog input operation, or an error will be reported.

Continuous Analog Output Operations

Continuous analog output operations are supported on the DT9837A module only. Use continuously paced analog output mode to continuously output buffered values to the analog output channel at a specified clock frequency.

Use software to fill multiple output buffers with the values that you want to write to the analog output channel. When it detects the specified trigger, the module starts writing the values from the output buffer to the analog output channel at the specified clock frequency. The operation repeats continuously until either all the data is output from the buffers or you stop the operation.

Note: Make sure that the host computer transfers data to the output channel list fast enough so that the list does not empty completely; otherwise, an underrun error results.

Allocating a minimum of two buffers for a continuously paced analog output operation is recommended. Data is written from multiple output buffers continuously; when no more buffers of data are available, the operation stops. The data is gap-free.

To stop a continuously paced analog output operation, you can stop queuing buffers for the analog output system, letting the module stop when it runs out of data, or you can perform either an orderly stop or an abrupt stop using software. In an orderly stop, the module finishes outputting the specified number of samples, and then stops; all subsequent triggers are ignored. In an abrupt stop, the module stops outputting samples immediately; all subsequent triggers are ignored.

Reading the Analog Output Value in the Analog Input Data Stream (DT9837A Module Only)

On the DT9837A module, you can read back the value of the analog output channel in the analog input data stream. Specify channel 7 in the analog input channel list to read back the value of the analog output channel. When the analog input operation is started, the value of the analog output channel is returned in the analog input data stream. (An analog value is returned.) The software automatically synchronizes the value of the analog output channel with the analog input measurements, so that all measurements are correlated in time.

Output Triggers

The DT9837, DT9837A, and DT9837C modules support the following trigger sources for starting analog output operations:

- **Software trigger** – A software trigger event occurs when you start the analog output operation (the computer issues a write to the module to begin conversions). Using software, specify the trigger source for D/A subsystem 0 as a software trigger.
- **External digital (TTL) trigger** – This trigger source is supported on the DT9837A and DT9837C modules. An external digital (TTL) trigger event occurs when the module detects a rising-edge transition on the signal connected to the Ext Trig BNC connector on the module. Using software, specify the trigger source for D/A subsystem 0 as an external, positive digital (TTL) trigger.

Note: If you configure the synchronization mode as slave, the RJ45 connector accepts trigger and clock signals from the master; you cannot use the Ext Trig BNC connector on the slave module.

- **Analog threshold trigger** – This trigger source is supported on the DT9837A and DT9837C modules. An analog threshold trigger event occurs when the signal attached to analog input channel 0 rises above a user-specified threshold value. Using software, specify the trigger source as a positive threshold trigger, the threshold trigger channel as analog input channel 0, and the threshold level as a value between 0.2 V and 9.8 V.

Note: If you configure the synchronization mode as slave, the RJ45 connector accepts trigger and clock signals from the master; you cannot use the analog threshold trigger on the slave module.

Triggering Acquisition on Multiple Modules

Note: For DT9837A, DT9837B, and DT9837C modules, you can synchronize acquisition on multiple modules using the RJ45 (LVDS) synchronization connector.

The internal clock on the DT9837 module and on the DT9837A and DT9837B modules when the synchronization mode is none, is derived from the USB clock and provides the timing for both the analog input and analog output subsystems on the module.

You can start acquisition on multiple modules by connecting all modules to a shared external trigger input. When triggered, the modules start acquiring data at the same time. Using this connection scheme, the measurements of one module may not be synchronous with the measurements of another module due to logic delays in the clocking and USB circuitry.

Synchronizing Acquisition on Multiple DT9837A, DT9837B, or DT9837C Modules

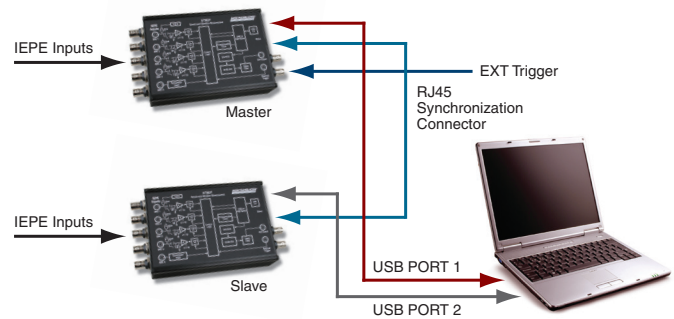

Figure 8. A Master/Slave connection allows two modules to operate in perfect synchronization for 8 IEPE inputs and 2 tachometer inputs.

DT9837A, DT9837B, and DT9837C modules provide an RJ45 (LVDS) synchronization connector that you can use to connect and synchronize multiple DT9837A, DT9837B, or DT9837C modules. In this scheme, one module is the master and the other modules are the slave. You specify the synchronization mode (master, slave, or none) of the RJ45 connector using software.

When configured as a master, the RJ45 synchronization connector outputs trigger and clock signals. When configured as a slave, the RJ45 connector accepts trigger and clock signals from the master; you cannot use the Ext Trig BNC connector or the analog threshold trigger on the slave module in this configuration. When configured as none (the default mode), the DT9837A, DT9837B, or DT9837C module uses the USB clock instead of the RJ45 synchronization connector. The synchronization mode remains set until changed or until the application exits.

You can connect multiple modules in one of two ways. Figure 8 shows how to connect a maximum of two DT9837A, DT9837B, or DT9837C modules by daisy chaining them together through the RJ45 connector.

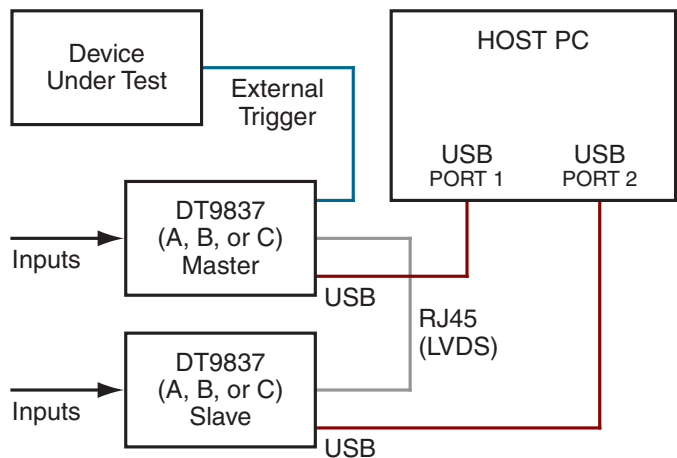

Figure 9. Synchronizing two DT9837 Series modules by daisy chaining the RJ45 connectors (shown using External Trigger).

Figure 10 shows how to connect a maximum of four DT9837A, DT9837B, or DT9837C modules by using an RJ45 distribution panel, where the panel contains four RJ45 connectors that are wired in parallel.

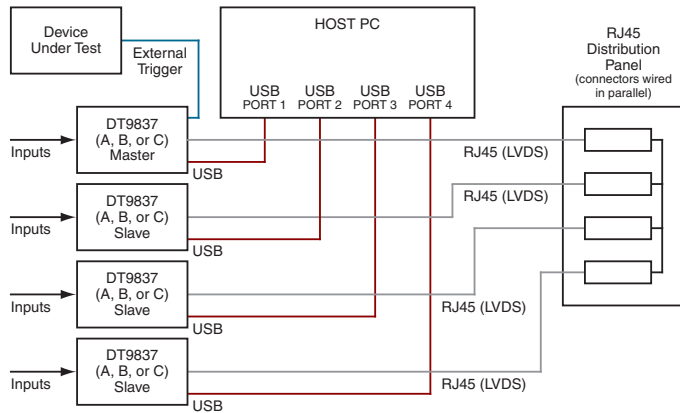

Figure 10. Synchronizing four DT9837 Series modules using an RJ45 distribution panel (shown using External Trigger).

When synchronizing multiple modules, start the slave modules before starting the master module. When the master module is triggered (using any of the supported trigger sources), both the master and the slave modules start acquiring data at the same time (within one A/D conversion of the clock). Note that you can set the clock rate to be the same or different on each module. When acquisition is stopped on the master module the slaves continue to run and return data until the analog input subsystem is stopped on the slave modules.

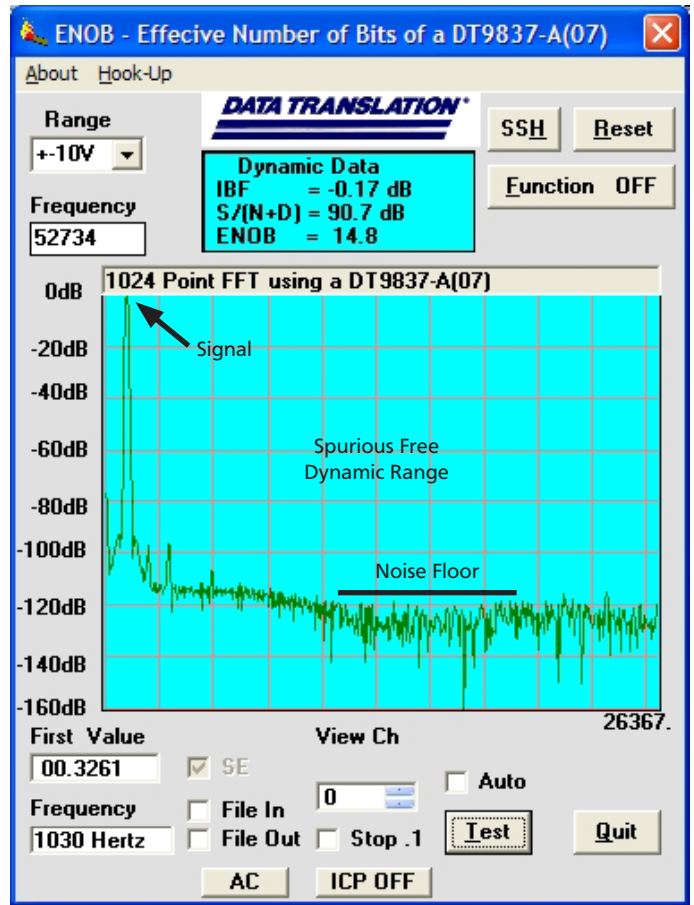

Figure 11. This graph shows the outstanding quality of the DT9837A for all error sources ... effective number of bits greater than 14.8 from all sources. The ENOBs for all DT9837 Series modules is similar as they use the same ADC and circuitry.

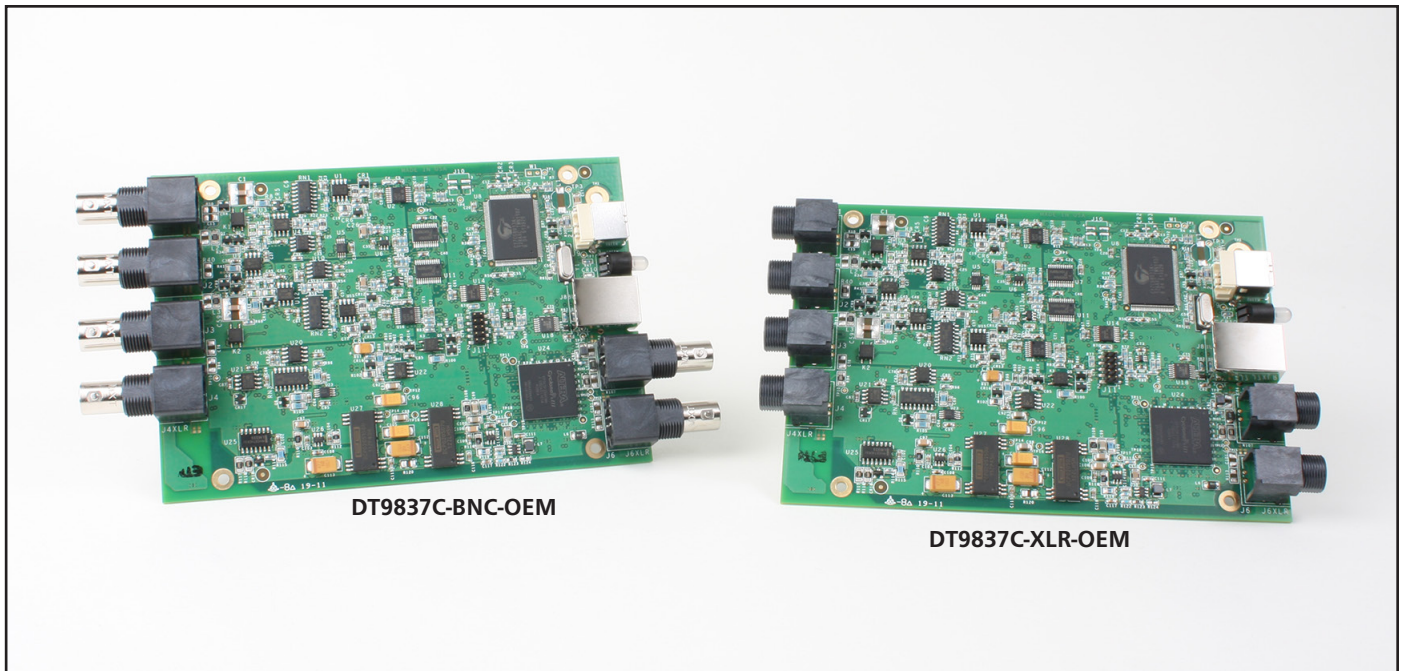

Figure 12. The DT9837C is targeted at audio and acoustics measurements. It is available as a board-level OEM product (as shown) or in a rugged metal enclosure with choice of mini-XLR or BNC connectors.

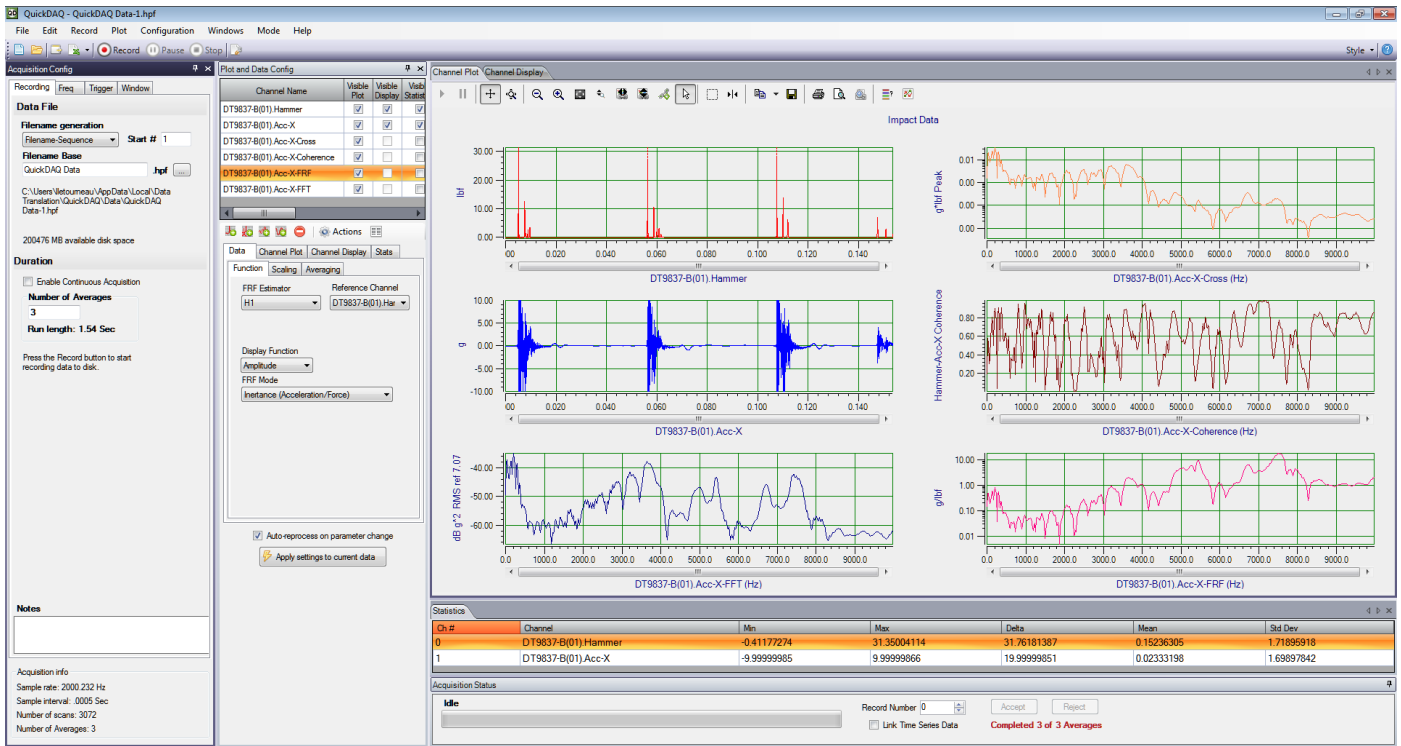

Figure 13. QuickDAQ with Advanced FFT Analysis Option.

QuickDAQ

QuickDAQ allows you to acquire and display from all Data Translation USB and Ethernet data acquisition devices that support analog input streaming. Combine QuickDAQ with Data Translation hardware to acquire data, record data to disk, display the results in both a plot and digital display, and read a recorded data file. Be productive right out of the box with this powerful data logging software. Data can be exported to other applications like Microsoft Excel® and The Mathworks MATLAB® for more advanced analysis. Two additional options can be purchased to add FFT analysis capabilities to the base package.

Key Features:

- **QuickDAQ Base Package (Free)**
 - Ready-to-measure application software
 - Configure, acquire, log, display, and analyze your data
 - Customize many aspects of the acquisition, display, and recording functions to suit your needs

- **FFT Analysis Option (License Required)**
 - Includes all the features of the QuickDAQ Base Package
 - Perform single-channel FFT operations including:
 - ◇ Auto Spectrum
 - ◇ Spectrum
 - ◇ Power Spectral Density
 - Configure and view dynamic performance statistics
 - Supports Hanning, Hamming, Bartlett, Blackman, Blackman Harris, and Flat Top response windows
- **Advanced FFT Analysis Option (License Required)**
 - Includes all the features of the QuickDAQ Base Package and FFT Analysis Package
 - Perform 2-channel FFT operations including:
 - ◇ FRF
 - ◇ Cross-Spectrum
 - ◇ Cross Power Spectral Density
 - ◇ Coherence
 - ◇ Coherent Output Power
 - Supports real, imaginary, and Nyquist display functions
 - Additional FFT analysis functions supported: Exponential, Force, Cosiner Taper
 - Save data to .uff file format

Other Software Options

The following software is available for use with this module and is provided on the Data Acquisition Omni CD:

- **Device Driver** – The device driver allows you to use the DAQ module with any of the supported software packages or utilities.
- **Calibration Utility** – This utility allows you to calibrate features of the DAQ module.
- **DT-Open Layers® for .NET Class Library** – Use this class library if you want to use Visual C#® or Visual Basic® for .NET to develop application software using Visual Studio® 2003-2012; the class library complies with the DT-Open Layers standard.
- **DataAcq SDK** – Use the Data Acq SDK to use Visual Studio 6.0 and Microsoft® C or C++ to develop application software using Windows® XP/Vista/7/8; the DataAcq SDK complies with the DT-Open Layers standard.
- **DAQ Adaptor for MATLAB** – Data Translation's DAQ Adaptor provides an interface between the MATLAB® Data Acquisition (DAQ) toolbox from The MathWorks™ and Data Translation's DT-Open Layers architecture.
- **LV-Link** – Data Translation's LV-Link is a library of VIs that enable LabVIEW™ programmers to access the data acquisition features of DT-Open Layers compliant USB and PCI devices.

Ordering Summary

All Data Translation products are covered by a 1-year warranty. For pricing information, please visit our website or contact your local reseller.

HARDWARE

- DT9837
- DT9837-OEM
- DT9837A
- DT9837A-OEM
- DT9837B
- DT9837B-OEM
- DT9837C-BNC
- DT9837C-BNC-OEM
- DT9837C-XLR
- DT9837C-XLR-OEM

ACCESSORIES

- BNC DIN Rail Kit
- EP386

FREE SOFTWARE

- QuickDAQ
- DAQ Adaptor for MATLAB
- LV-Link

OPTIONAL SOFTWARE

- QuickDAQ FFT Analysis Option (License Required)
- QuickDAQ Advanced FFT Analysis Option (License Required)